

HiFi ENGINE®

For more Hi-Fi manuals and set-up information
please visit www.hifiengine.com



YAMAHA

AM/FM STEREO RECEIVER

CR-2040

OWNER'S MANUAL



CR-2040

CONNECTION DIAGRAM

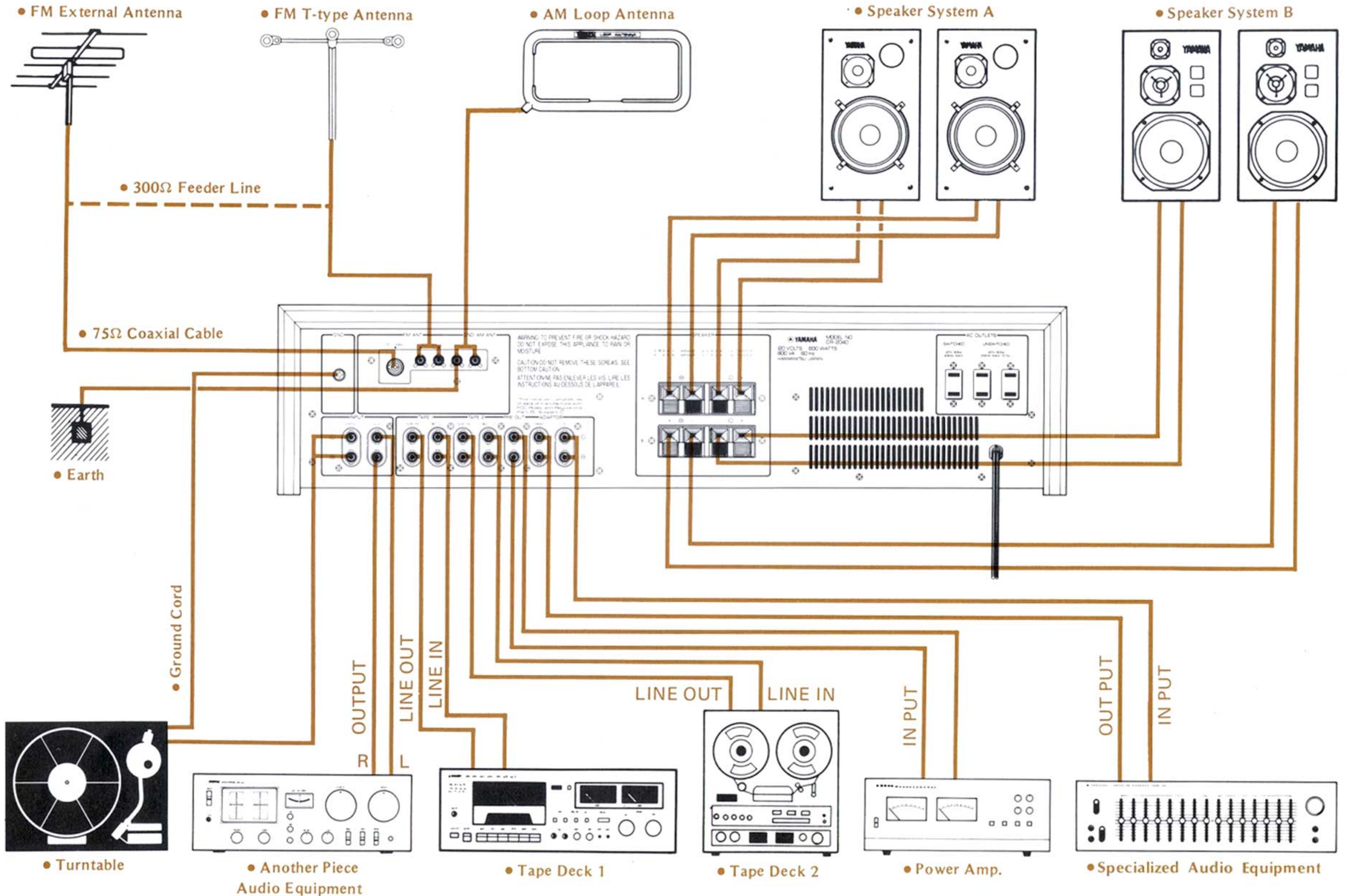

FRONT PANEL

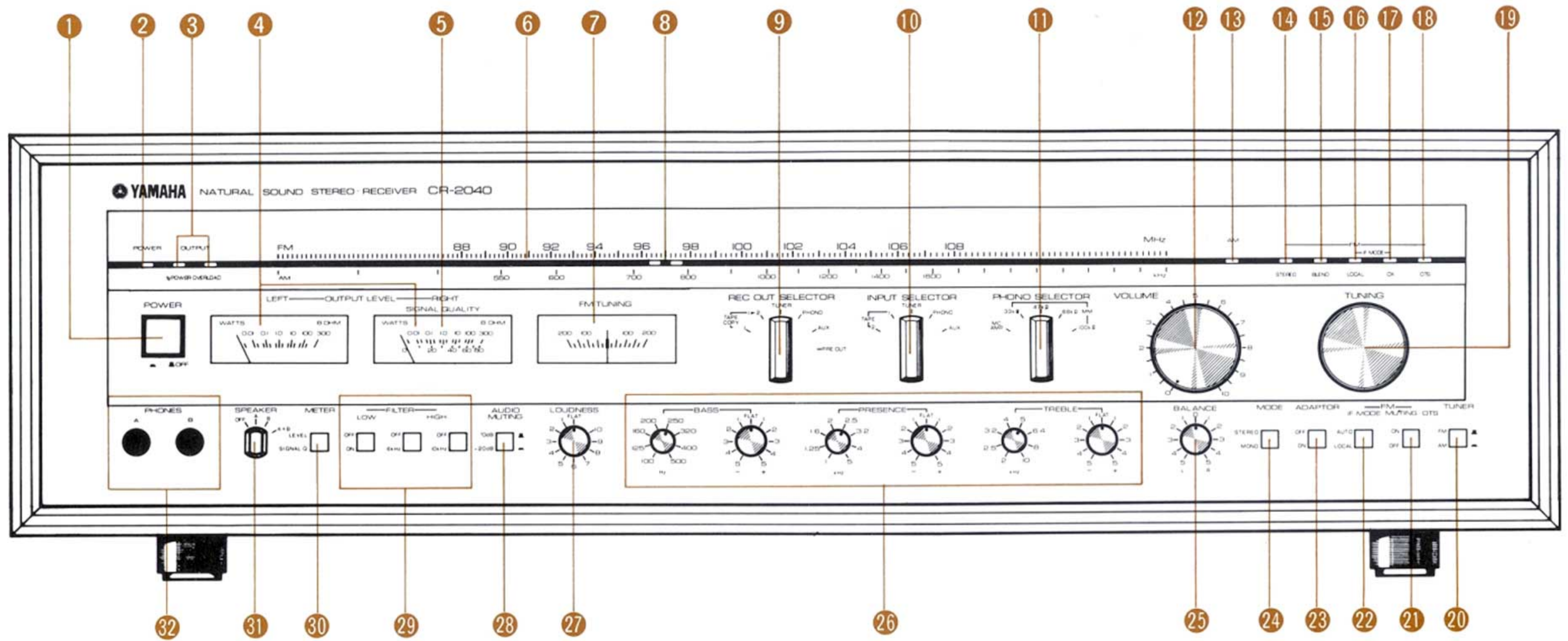

REAR PANEL

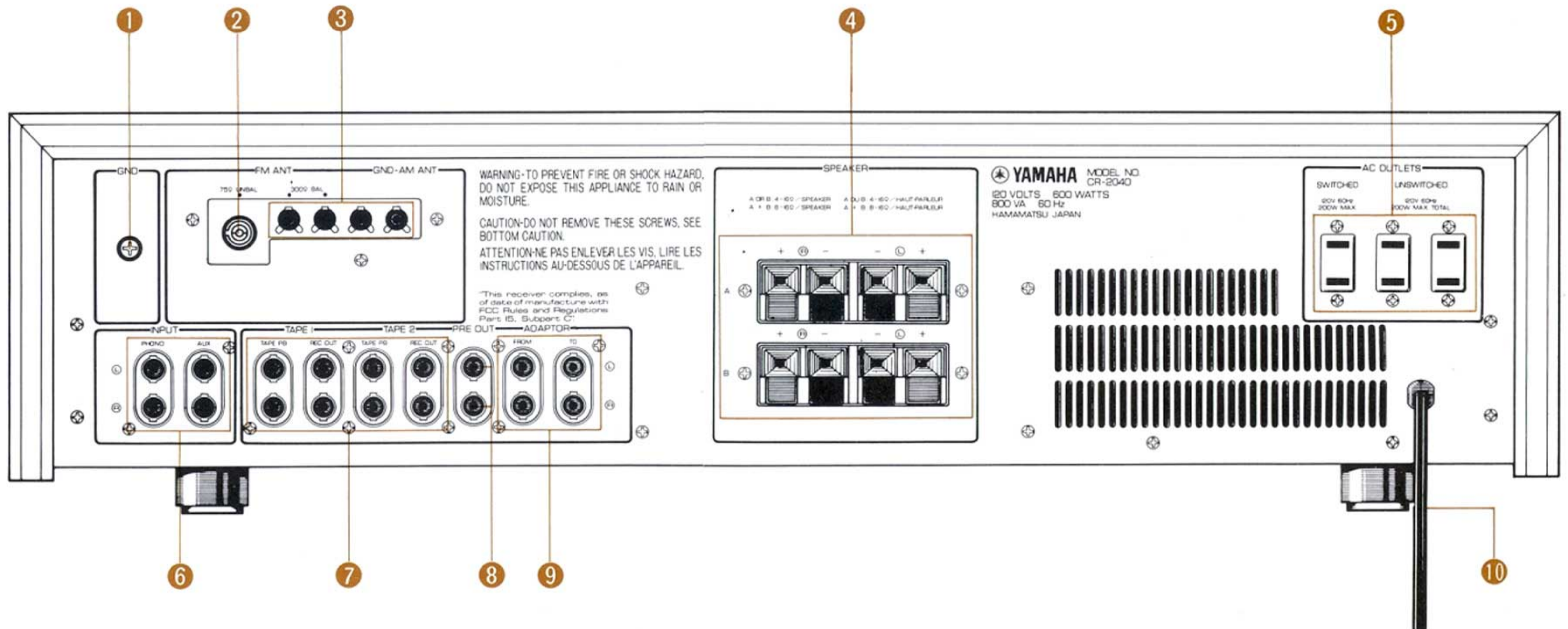

Yamaha offers you thanks and congratulations on your choice of the CR-2040 Receiver

By including a wide range of up-to-date and very practical features, the CR-2040 achieves superb broadcast reception with a very high quality of sound reproduction, currently setting new standards for receiver performance in this class.

FEATURES

1. All In One Excellence

Accurately matched performance specifications and controls give overall performance which fully measures up to YAMAHA's high tuner, pre-, and power amplifier standards.

2. Noise-Distortion Clearance Range

The basic concept behind the design of the audio section includes an extremely high output power rating at which both noise and distortion are extremely low. A very wide dynamic range is also achieved.

3. Direct Assessment of Differential Gain

This sophisticated technique enables YAMAHA to combine high sensitivity with razor-sharp tuning selectivity and ultra-low distortion in the tuner section.

4. Optimum Tuning System

The OTS system automatically performs the fine-tuning task needed to obtain minimum distortion and maximum stereo separation so that all FM stereo programs are heard at their very best.

5. Multi-Function Meters

Fast-response peak-reading meters indicate power output levels from 0.01W to 300W (for 8Ω speakers), with the right channel meter doubling as signal strength and FM signal quality meter.

6. Three Separate Tone Controls with Continuously Variable Turnover Frequencies

The CR-2040 has been designed with two independent tone controls, each with an independent and continuously variable turnover frequency. Low, and high frequencies may thus be adjusted precisely to the desired levels to compensate for listening room or program source deficiencies. Also, with the PRESENCE range the center frequencies can be selected in continuously-variable mode.

7. Continuous Loudness Compensation

This YAMAHA 'special' enables full compensation for your ear's reduced sensitivity to bass and treble frequencies at low listening levels.

8. Super Low-Noise Mc Head Amp

The CR-2040 also includes an MC head amp stage to permit direct use of low output moving coil cartridges with their subtle differences in performance. There is no need for a separate step-up transformer or head amplifier.

9. IF Mode Switch and Auto FM Blend Circuit

The CR-2040 also includes an automatic FM blend circuit in the IF mode switch, thereby ensuring optimum reception quality and stability with both strong and weak broadcast alike.

CONTENTS

Connection Diagram	2
Front Panel and Rear Panel	3
Cautions—Read This Before Operating	
Your CR-2040.	5
Front Panel and Controls	6
Rear Panel and Connections.	9
Broadcast Reception	11
Listening to Records	15
Loudness Control and Tone Controls	16
Rec Out Selector	17
Tape Deck Connection	18
Filters and Adaptor Switch	19
Specifications	20
Block Diagram	22
Schematic Diagram	23
Trouble Shooting	24

IMPORTANT!

Please record the serial number of your unit in the space below

Model Name CR-2040

Serial No. _____

The serial number is located on the rear of the chassis.

Retain this Owner's Manual in a safe place for future reference.

CR-2040

CAUTIONS — READ THIS BEFORE OPERATING YOUR CR-2040

1

The CR-2040 is a high performance AM/FM stereo receiver with excellent selectivity, sensitivity, and very low distortion. Read this manual carefully in order to ensure that you get optimum performance from its unique features.

2

Do not knock or otherwise jar the CR-2040, a high-precision electronic instrument.

3

Do not place the CR-2040 where it will be exposed to direct sunlight, excessive heat (near a radiator for instance), cold, moisture or dust.

4

Do not use chemical solvents (such as benzene or alcohol) to remove traces of dirt. Wipe only with a soft, slightly damp cloth.

5

The CR-2040 is quite heavy. When installing, be sure to select a firm and solid base.

6

Do not attempt to carry out any internal adjustments or repairs. Leave these to your local authorized service representative.

7

When something appear to be wrong, do not jump to the conclusion that your CR-2040 is at fault. First check the 'Trouble Shooting' chart on page 24 to 25.

8

Operate all switches and knobs as instructed. Never apply undue force, and do not attempt to use in between switch positions.

9

Do not connect other audio equipment to the AC outlet sockets on the rear panel if that equipment requires more power than the specified rating.

10

Keep this manual in a safe place for future reference, and refer to it frequently until you are completely familiar with all CR-2040 controls and functions.

Warning — to prevent fire or shock hazard, do not expose this appliance to rain or moisture.

CR-2040

FRONT PANEL AND CONTROLS

1 POWER ON/OFF Switch

Switch ON to activate the mains power supply: Leave OFF while familiarizing yourself with the controls, and while connecting other audio equipment.

2 POWER Indicator

This light-emitting diode indicates when the power being ON.

3 1/2 POWER OVERLOAD Indicator

The maximum output depends on AC mains voltage and the impedance ($4\Omega \sim 16\Omega$) of the speaker system connected to the speaker terminal. The 1/2 POWER indicator illuminates when the output reaches the half of the maximum.

When left or right output power levels exceed a certain level, resulting in increased distortion (about 1% T.H.D. 8Ω), the OVERLOAD indicator will illuminate, indicating the overloaded condition. To correct this, turn the input level down by turning the volume control counter-clockwise.

4 LEVEL Meters

These sensitive, wide-range meters measure the output power in left and right channels from 0.01W to 300W. The right hand meter also doubles as the signal strength and quality meter (switching over to this function when the tuning knob is

touched). It can also be switched to read signal quality permanently.

5 LEVEL/SIGNAL QUALITY Meter

This meter indicates the strength of the signal for both AM and FM stations, and also indicates the presence of FM interference by fluttering of the indicator pointer the degree of deviation indicating the extent of the interference. It also indicates approximate S/N ratio, and doubles as an output level meter.

6 FM/AM Tuning Scale

The upper scale gives FM station frequencies in MHz, and the lower scale gives AM frequencies in kHz. On the right hand side of the dial scale, LEDs light up to indicate FM or AM.

7 FM TUNING Meter

This is used when tuning FM stations: the indicator points to dead center when the station is perfectly tuned.

8 Dial Pointer

This pointer indicates accurately the frequency of the station to be tuned in.

9 REC OUT SELECTOR

This switch selects the signals to be recorded by the tape deck connected.
Since the REC OUT SELECTOR is completely in-

dependent from the INPUT SELECTOR, you can listen to one program source while simultaneously taping another (from the rear panel REC OUT terminals).

With this switch set to the PHONO position, you can also operate the PHONO SELECTOR switch 11 according to the type of your cartridge (MM or MC) or the impedance.

* Please refer to Page 17 for instructions.

10 INPUT SELECTOR

This switch is used to select the program source: PHONO, TUNER, AUX (8-track tape player, etc.), TAPE 1 or TAPE 2.

11 PHONO SELECTOR

This switch permits selection of an input circuit to match the phono cartridge being used when the INPUT SELECTOR is set to PHONO position.

12 VOLUME Control

Use this control to adjust suitable volume levels. Always start with it turned fully counter-clockwise to the "0" position before turning up to the required volume level.

13 AM Indicator

This indicator comes on when receiving AM broadcasts.

14 **STEREO Indicator**

This indicator comes on automatically when an FM stereo broadcast is received, and goes out automatically when the broadcast switches to monaural.

Note that STEREO indicator LED lights up when receiving to a stereo broadcast.

15 **BLEND Indicator**

This indicator comes on automatically when the signal you receive is weak. In weak reception areas, when a hissing or high pitched noise makes for poor FM stereo reception, the blend circuit will cut in to eliminate the high-range noise. Note that it operates only when the IF MODE switch is in the AUTO () position.

16 **LOCAL Indicator**

This indicator lights up during reception of local strong stations. When the IF Mode Switch is in the LOCAL () position, however, it lights up regardless of distance or strength. This position further reduces distortion for reception of over broadcasts with crystal clear sound and very high resolution.

17 **DX Indicator**

If the DX indicator light is on when the IF MODE switch is in the Auto () position, it signifies that the tuner is operating in the DX mode. When tuned to a powerful local station, the CR-2040

switches over to LOCAL mode and the LOCAL indicator lights up. In the Auto () position you get maximum suppression of interference as well as excellent selectivity when listening to weaker signals.

18 **OTS Indicator**

If the OTS indicator light is on when the FM MUTING/OTS switch is in the ON () position, the Optimum Tuning System will correct any slight mis-tuning to assure optimum reception of FM broadcasts at all times.

19 **TUNING Knob**

This large precision flywheel type tuning knob is designed for smooth and rapid station tuning. When the knob is touched by hand during FM or AM reception, the LEVEL/SIGNAL QUALITY meter will switch over automatically to operate as signal quality meter. The OTS circuit is thus switched off, and the OTS indicator turned off during the FM reception.

20 **TUNER FM/AM Switch**

This determines whether AM or FM stations will be received.

21 **FM MUTING/OTS Switch**

When this switch is ON (), the Optimum Tuning System (OTS) will minimize the effect of mis-tuning, and will ensure continued optimum-recep-

tion of FM broadcasts. In the OFF () position, accurate manual tuning will be required. Even in the ON position, however, OTS is automatically switched off when the tuning knob is touched, thereby permitting manual tuning. The FM muting function ensures that both inter-station noise and weak signal strength stations will be muted. In the OFF position even the weakest stations will be heard.

22 **IF MODE Switch**

When this switch is in the AUTO () position, it insures automatic switching to DX mode in case you receive weak signals and to LOCAL mode in reception of strong signals.

The switch in LOCAL () position permits low-distortion and quality signal reception.

23 **ADAPTOR Switch**

When connecting a graphic equalizer, Dolby unit or any other audio equipment to the Adaptor terminals, turn the ADAPTOR switch to ON. Make sure to turn it to OFF again when not in use.

24 **MODE Switch**

In the mono position the amplifier section will reproduce all sounds (including FM stereo programs) monaurally. Signals reaching REC OUT terminals, however, become monaural only when REC OUT SELECTOR is positioned in PRE OUT.

25 **BALANCE Control**

The balance control varies the difference in output volume between the L and R (left and right) stereo channels. Set this control to the center "0" click-stop position unless you need to correct for a lack of balance between the output of the two channels, or to correct for listening room conditions. The balance control reduces the volume from the left hand speaker when turned clockwise, and reduces that from the right hand speaker when turned counter-clockwise.

26 **BASS, PRESENCE, and TREBLE Controls**

The CR-2040 features a very comprehensive tone control system. Tone response in the low (BASS), mid-range (PRESENCE), and high (TREBLE) frequency regions may be boosted or attenuated by each of the right hand controls, while the independent turnover frequencies for BASS (100Hz ~ 500Hz) and TREBLE (2kHz ~ 10kHz) may be freely varied to any value within the specified ranges. Also, with the PRESENCE region the peak frequency for boosting or attenuation may be varied continuously within the range of 1kHz to 5kHz.

27 **LOUDNESS Control**

This boosts the extreme low and high frequencies to compensate for the reduction in the human

ear's sensitivity to these frequencies at low volumes. Set to the FLAT position when the VOLUME control is set to normal listening level. Turning counter-clockwise will reduce the volume while retaining the natural balance between low and high frequencies.



28 **AUDIO MUTING Switch**

This provides a 20dB reduction in listening level without having to adjust the volume control. Use it whenever operating selectors or other switches, and when lowering the phono cartridge onto the record.

29 **LOW and HIGH FILTER Switches**

The low filter gives a sharp 12 dB/octave cut-off below 25Hz, while the high filter has a 6 dB/octave cut-off slope for frequencies above 6 kHz, or 10kHz.

30 **METER Switch**

The meters operate as output level meters when the LEVEL/SIGNAL Q switch is left out in the LEVEL () position, while the right hand meter operates as a SIGNAL QUALITY meter (indicating both strength and quality of the tuned signal) when pushed in to the SIGNAL Q () position.

Note: If this switch is left out in the LEVEL () position during FM or AM reception, the right hand meter will automatically

switch over to operate as signal meter whenever the tuning knob is touched. As soon as the hand is released, it again operates as output level meter.

31 **SPEAKER Selector**

With this switch you can select either A or B, or A + B if two sets of stereo speaker systems are connected.

32 **PHONES Jacks**

Two headphone jacks are provided. Plugging into the jacks does not cut-off power to the speakers, for it is necessary to use the OFF position of the SPEAKER selector switch if you do not want the speakers to function.

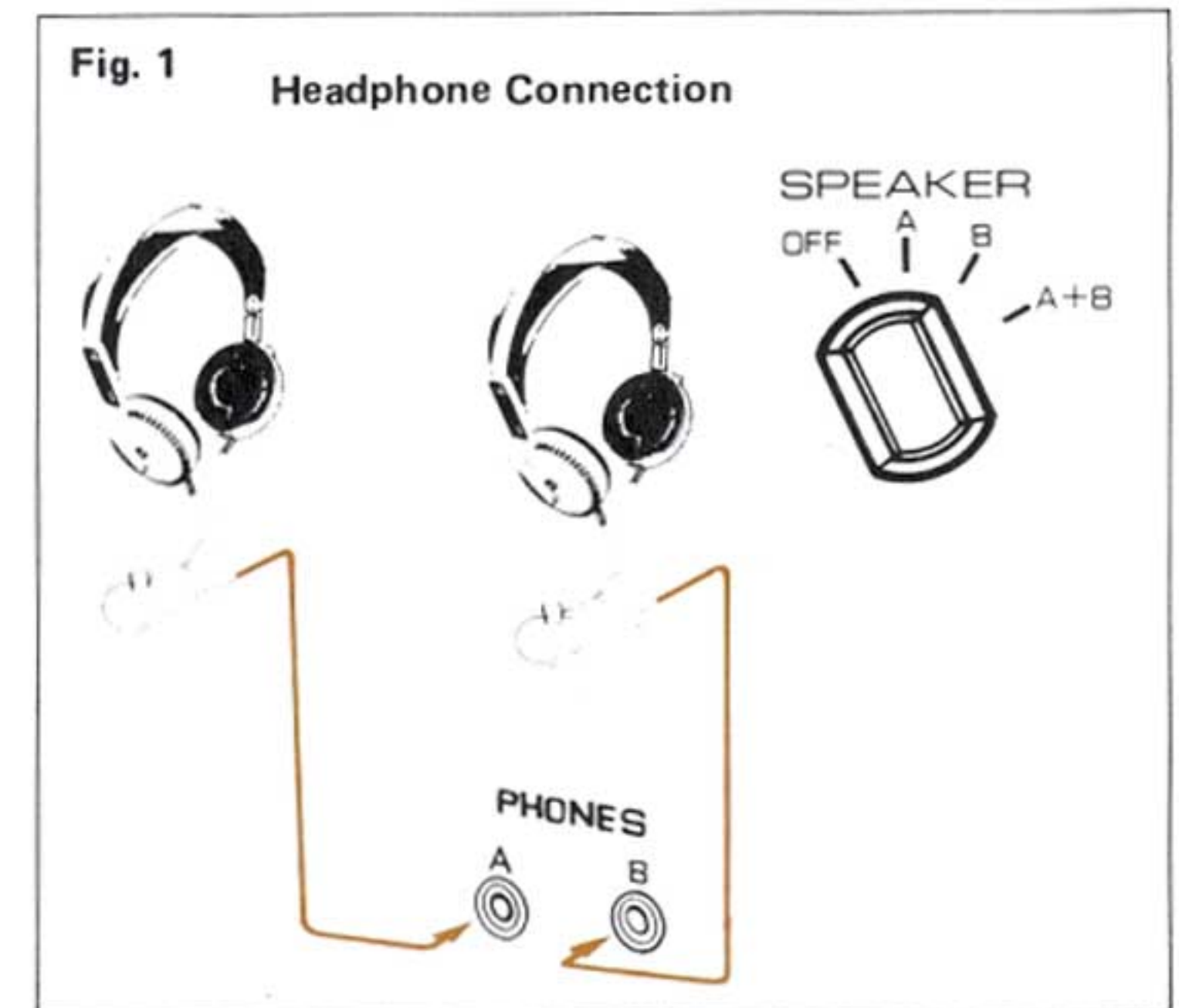

CR-2040

REAR PANEL AND CONNECTIONS

1 GND (Ground) Terminal

The ground terminal is provided for grounding turntables.

2 FM ANT 75 Ω UNBAL

The 75 Ω UNBAL (unbalanced) terminal is used for an unbalanced type 75 Ω coaxial cable. (Refer to P. 11)

3 Antenna Connections

Detailed instructions on AM and FM reception are given on pages 11 to 14, but a quick check of tuner functions can be carried out by connecting the T-type indoor antenna provided with the CR-2040 to the terminals marked 300 Ω BAL. Attach the two arms of the "T", fully extended, to the ceiling or walls of your room. The quick check can be carried out with the selector switches vertical and all push button switches in the out (non-depressed) positions, except for the SPEAKER selector switch-(when you wish to hear the output on your speakers rather than using headphones).

4 SPEAKER Terminals

The CR-2040 can handle two sets of speakers (A and B), with selection of either, both, or neither, by use of the SPEAKER selector switch on the front panel. Speakers should have impedances from 4 to 16 Ω, but when two speaker sets are to be

used at the same time, connect only speakers with impedances from 8 to 16 Ω. Use speakers capable of handling the full 120 watts of output power, or set the volume control so that the rated maximum speaker input power is not exceeded. Volume level should be reduced immediately whenever there is increased distortion or a sense of strain which indicates that the speakers are being overloaded.

Speaker Connections

1. Strip 1/2" of insulation from the speaker cable and twist the wire ends together. If possible solder the ends. Push the lever beneath the terminal as shown in the diagram, aligning the inner and outer terminal holes. Then fully insert the stripped wire. Release the lever to firmly clamp the wire end.
2. Use the upper (A) terminals first. Be careful that the terminals identified by the + and - signs above them are connected to the corresponding + and - terminals on the speakers. A mistake will result in poor bass response and ill-defined stereo image. Also be sure to connect the left hand speaker to the L speaker terminals, and the right hand to the R terminals.
3. Repeat this with the B terminals if other speakers are to be connected. In all cases make sure that connections are firm and secure, otherwise you may not be able to get any sound from one or more speakers.

Fig. 2

Speaker Connections

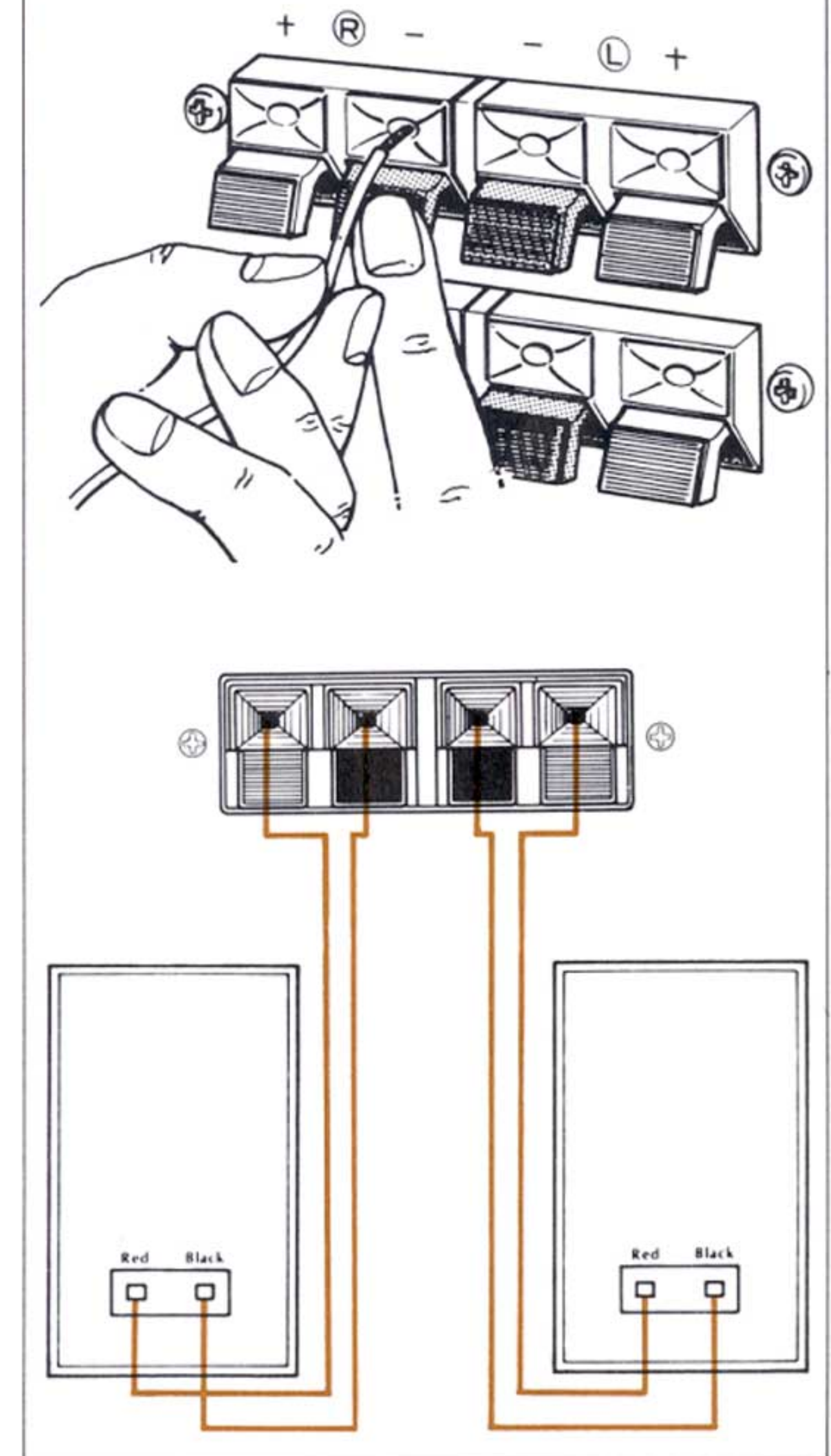

5 AC OUTLETS

These spare AC outlets are provided for convenience in connecting other audio equipment. Only the left outlet is coupled to the CR-2040 power switch. This has a maximum power rating of 200 watts, and should be used for components such as turntables. Do not connect any equipment which consumes more than 200 watts. The other outlets are not coupled to the CR-2040 power switch, so any components connected to these outlets must be switched on and off by their own power switches. Note that the total power rating for these other two outlets together is 200 watts. They are ideal for tape decks.

6 INPUT Terminals

These are the terminals used for PHONO and AUX connections, and selected by the INPUT SELECTOR on the front panel. The AUX terminals can be used to connect an external tuner, or 8-track cartridge tape player, etc.

7 TAPE PB and REC OUT Terminals

Two tape decks can be attached to these input and output terminals. Recording of any source connected to the CR-2040 can be made on both tape decks at the same time by setting the REC OUT SELECTOR on the front-panel to the

appropriate position. Tapes can be dubbed from one deck to the other in either direction, and recording can proceed while any other source selected by the INPUT SELECTOR is being auditioned.

8 PRE OUT Terminals

Connect the PRE OUT terminals to the INPUT terminals on a power amplifier by means of connecting cords.

9 ADAPTOR Terminals

When connecting a graphic equalizer, Dolby unit or any other audio equipment to the adaptor terminals, connect the output terminals to the FROM terminal on the rear panel of the CR-2040 and the input terminals to the TO terminals.

10 AC Electrical Power Line

Plug the CR-2040 power cord into the mains power supply wall outlet socket, and make sure the line is not left loose where it is likely to be tripped over.

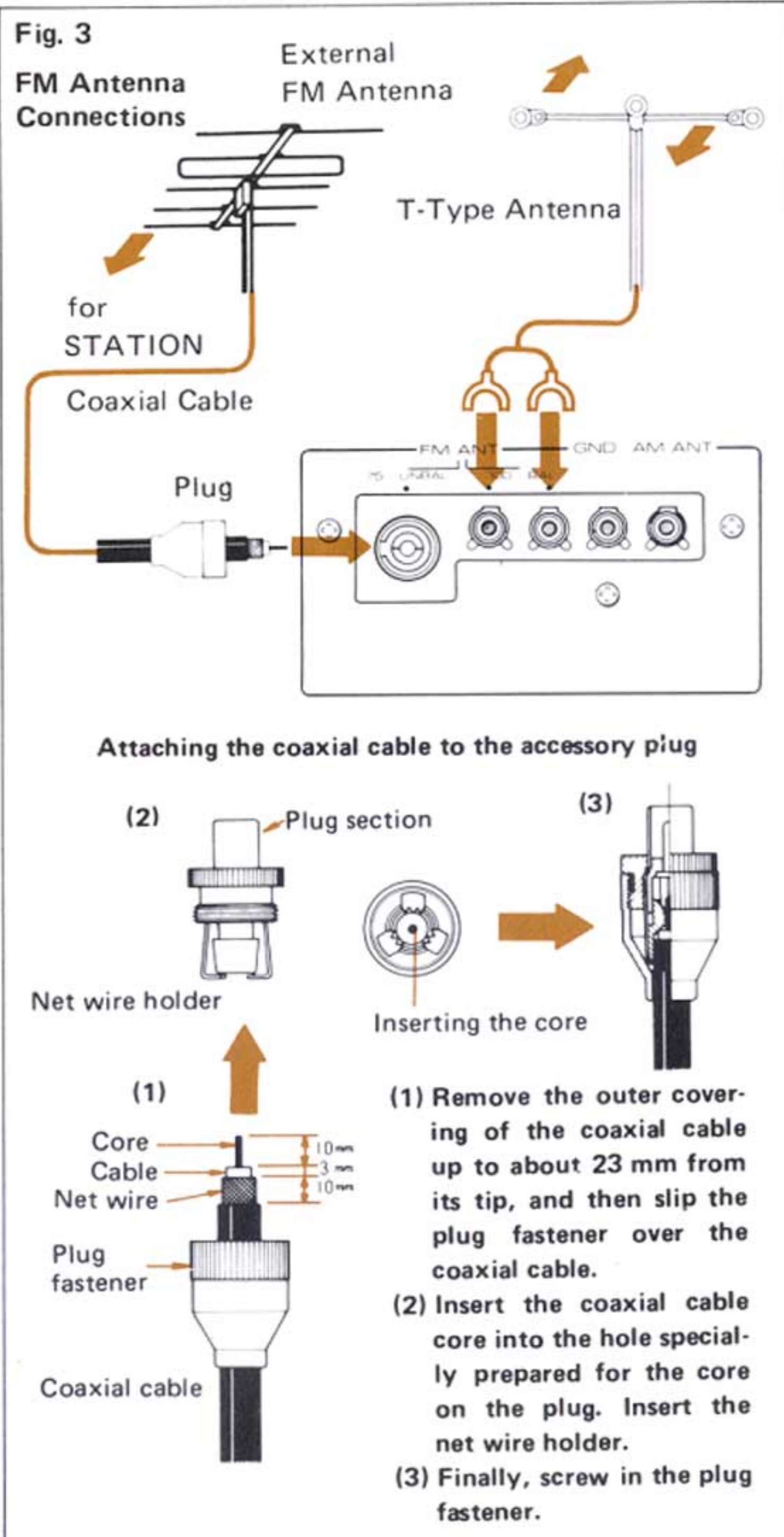

CONNECTING AM FM ANTENNA

The T-type antenna provided with your CR-2040 is adequate in high signal strength areas and under favorable conditions. In less favorable conditions, an external multi-element FM antenna will be needed. If you cannot obtain satisfactory reception with the T-type antenna, this is an indication that you need an external FM antenna. To ensure the very best results, a motor-driven antenna assembly with remote control is ideal, but the CR-2040 has sufficient sensitivity to operate well with a fixed antenna. The external antenna should preferably be located fairly close to the CR-2040, and mounted as high as conveniently possible. Try various antenna directions, either pointing towards the weakest station you intend to receive or away from the major source of interference (preferably both, although some compromise is

usually necessary in most locations). If the antenna is intended for use with shielded coaxial cable (which reduces losses and interference) use the 75Ω UNBAL terminals on the rear panel of the CR-2040, and connect the cable as shown. Antennas intended for use with the 300Ω BAL terminals on the rear panel (which use feeder wire similar to that of the internal antenna provided) can also be used with coaxial cable if a matching transformer is attached to the antenna. The use of coaxial cable is advisable where the antenna must be located some distance from the CR-2040, or where interference from automobile ignition or other sources is noticeable.

When connecting the coaxial cable to the 75Ω UNBAL connector located on the rear panel of the CR-2040, first attach the cable to the accessory plug as shown in the diagram.

FM BROADCAST RECEPTION

1. Set the INPUT SELECTOR to TUNER.
2. Set the TUNER push-button to FM.
3. Check that the FM indicator LEDS light up at the right hand side of the dial.
4. All switches and knobs should be as shown in the Page 3.
5. Tune for maximum signal strength on the

- SIGNAL QUALITY meter, ignoring any regular oscillations of the indicating pointer position.
6. Now tune to bring the FM TUNING meter pointer to the exact center. This is the optimum tuning position, so set it carefully.
7. Note that the STEREO indicator LED lights up when listening to a stereo broadcast.

IF MODE AUTO/LOCAL SWITCH

AUTO Position

For normal FM reception, set the switch to AUTO position. Setting the switch to this position permits the following operations to be performed.

During tuning:

High sensitivity and high selectivity is ensured in DX mode. The DX indicator lights.

After tuning:

- In the case of strong signal and low interference, the mode is automatically changed to LOCAL mode, permitting low-distortion and wide frequency range reception.

(LOCAL indicator lights up.)

- If the station signal weakens or a strong interference is given again, it is automatically switched from the LOCAL mode to the DX mode. (DX indicator lights up.)

LOCAL Position

If the station signal is strong with no crosstalk or interference, set the switch to LOCAL position. Low-distortion and wide frequency range reception is then ensured.

Suppose you are receiving such a broadcast as not allowing automatic switching to LOCAL mode in the AUTO position and still you want reception of low-distortion over a wide frequency range, set the switch to LOCAL position.

FM MUTING/OTS SWITCH

This push-button switch should normally be left in the ON position. If pushed into the OFF position, it will over-ride the OTS circuit, allowing full manual tuning, but preventing the automatic correction of slight mistuning or drift due to the influence of temperature and humidity.

Switch OFF for reception of weak stations near powerful local stations which might be locked in, by the OTS. If the weaker stations are not strong enough for enjoyable listening, leave this control in the ON position. The weaker stations will be cut out along with interstation noise. You will be able to tune from one station to another in silence free of background noise and remote, poor quality stations.

Fig. 4 IF MODE Switch

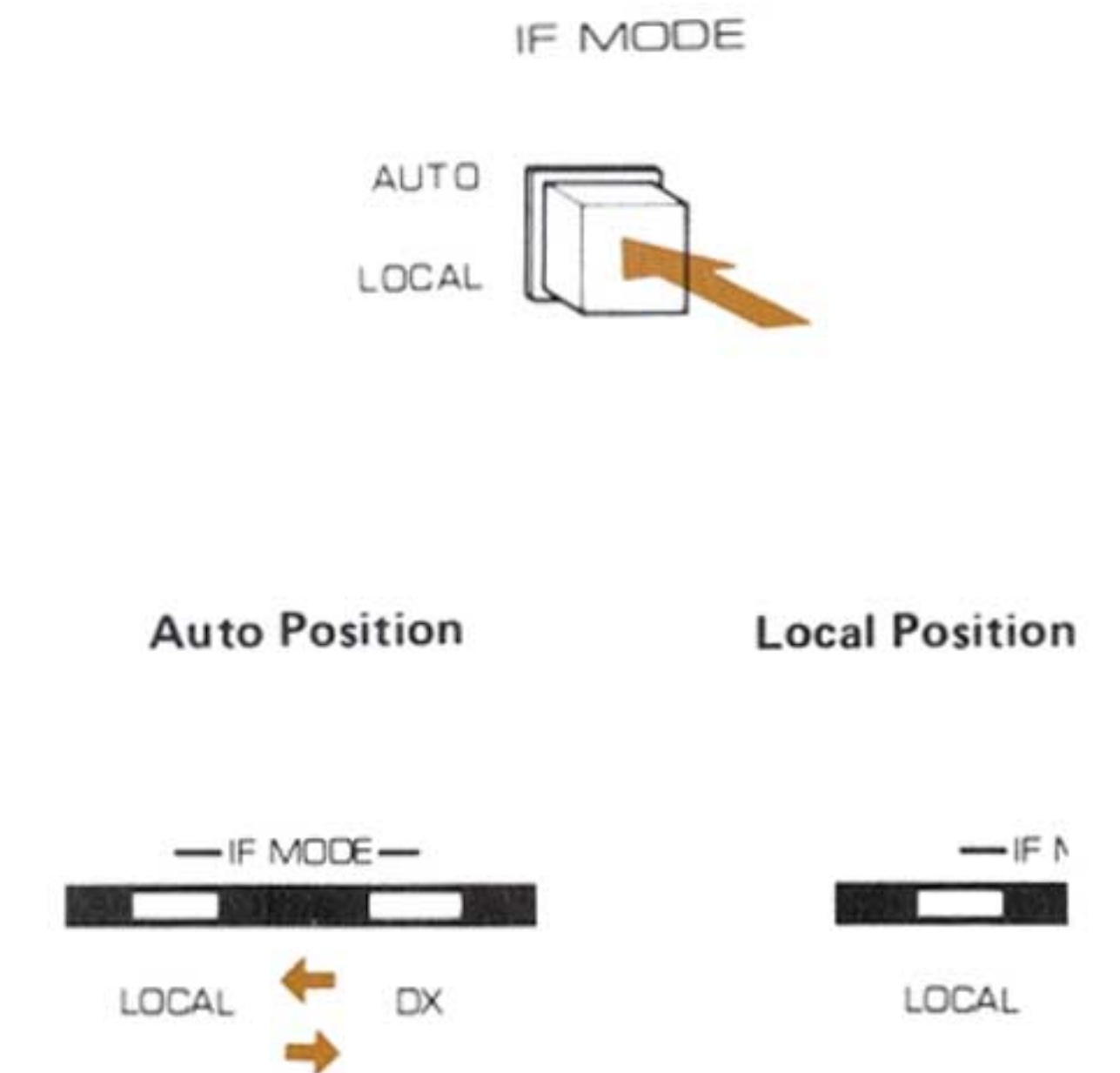

Fig. 5 MUTING/OTS Switch



SIGNAL QUALITY METER

Besides indicating signal strength of AM and FM broadcasts, the SIGNAL QUALITY meter also indicates FM signal quality. When so-called 'multipath' waves reflected from nearby hills or tall buildings are present, the meter pointer will oscillate back and forth, centering on the average signal strength. If you notice such variations in value of the the SIGNAL QUALITY meter readings, try different antenna directions. You will generally enjoy better tonal quality if you set the antenna to give a steady reading, even if this level is a little lower than the maximum level obtained when the indicator was fluctuating.

Fig. 6 Signal Quality Meter Deflection



MULTIPATH DETECTION

FM multipath is somewhat like the TV "ghost" phenomenon. As shown in Fig. 7, some FM signals are received directly by the antenna while others reach it from other directions, bouncing off buildings or mountains. The latter are called multipath waves. These are received only slightly later than the direct waves, and this causes some distortion in the sound and deterioration in separation and tonal quality. This multipath effect can be minimized by using a tall antenna with good directional characteristics and by carefully setting antenna direction.

During FM reception, a delicate quiver of the signal meter indicator indicates multipath interference.

Change antenna direction or position so as to stabilize the indicator.

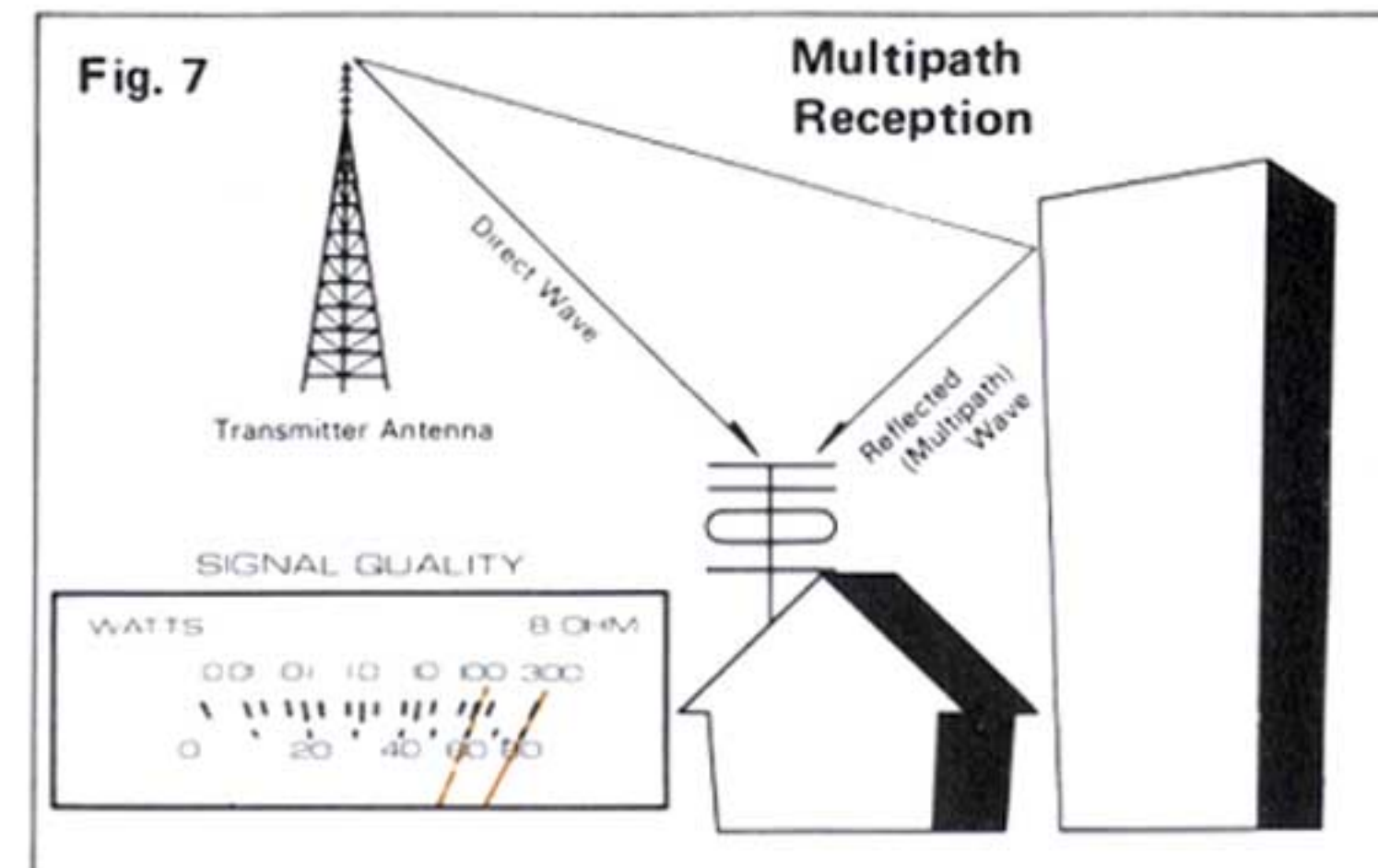

AM RECEPTION

First set the TUNER FM/AM switch to AM, and set the dial pointer to the desired station frequency. Adjust the tuning knob to give the maximum SIGNAL meter reading. Note that the FM TUNING meter does not function for AM stations. If the FM antenna is used for an AM antenna, install the combination bar as in Fig. 12.

Fig. 8 TUNER



USING THE LOOP ANTENNA

Your Yamaha Loop Antenna is a special, low-noise antenna for AM broadcasts. Always be sure to connect it to your receiver. Otherwise, AM broadcasts may not be received.

1. Installation position

This antenna can be mounted to the rear panel of a receiver, rear of a rack, or on a wall. Install it as far away from noise sources as possible.

2. Installation method

Peel the seal off the rear of the antenna holder, position the adhesive side of the holder at the position you wish to install it, and push the holder against the panel, wall, or rack firmly.

Note: Since the adhesive is extremely strong, be sure to position the holder correctly before mounting it securely.

3. Loop antenna

The loop antenna can be detached from the holder and installed by either of the two methods illustrated in the Fig. 11. Use the method which provides the best reception.

CONNECTING THE LOOP ANTENNA

Remove the combination bar and connect the cord

LOOP ANTENNA AND AM BROADCAST

Since the AM broadcast frequency band is a low 500 kHz ~ 1,600 kHz, its wavelength is approximately 300m at 1,000 kHz and the use of a long antenna is ideal for noise-free reception. However, an FM antenna is actually used as an AM antenna and AM long distance reception is possible.

Therefore, satisfactory reception may be impossible where the receiving conditions are poor (such

from the loop antenna to the ANTENNA AM and GND terminals on the rear panel of the receiver. If the combination bar is not removed, good reception will not be obtained.

USING THE LOOP ANTENNA

Adjust the direction of the loop antenna for best reception as shown in the Fig. 13.

as inside a building and near fluorescent lamps, thermostats, motors, or discharge lamps).

Use this loop antenna by referring to the following table.

This loop antenna is designed to be used vertically. If used otherwise, its reception sensitivity reduce expensively. So, please do not fail to use it vertically all the time.

Conditions and Symptoms when receiving AM broadcasts with the Loop Antenna

Receiving Conditions – What antenna are you using in what room?		Symptom – What are the receiving conditions of the AM broadcast you want to receive?
Room	Antenna	
Inside Building	T-type FM antenna	AM broadcasts cannot be received.
Inside Building and near *Noise sources.	T-type FM antenna	Very Noisy (Signal meter pointer deflects only slightly.)
Not inside Building, but near *Noise sources.	T-type FM antenna (with lead wire extension)	Very Noisy (Signal meter pointer deflects only slightly.)
In a room near a power line.	T-type FM antenna	Modulation hum is loud.
Near a high tension line.	Outdoor antenna or Community antenna	
Broadcast station signal is strong, but antenna is near indoor wiring and *Noise sources.	T-type FM antenna, Outdoor antenna, or Community antenna	Interference.

* **Noise sources:** Fluorescent lamps, thermostats, motors, discharge lamps, and other electrical devices.

• Under the conditions except the above figure, use the combination bar.

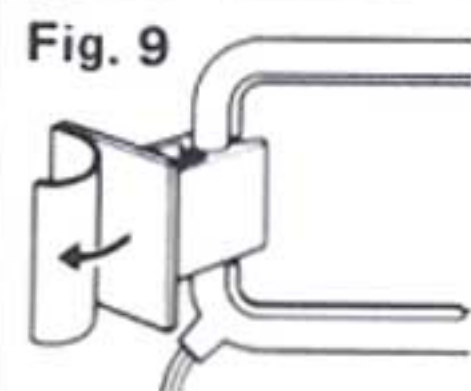

Remove this seal and attach the holder by pushing it firmly against the panel, wall, or rack.

Fig. 10

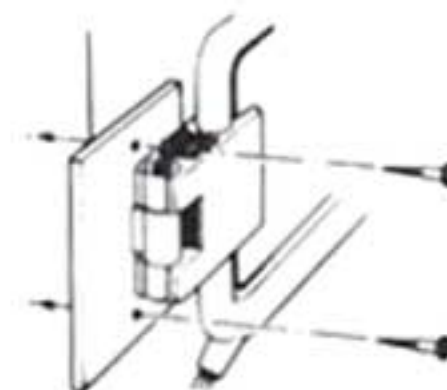

The holder may also be installed to the panel, wall, or rack with nails or wood screws.

Fig. 11

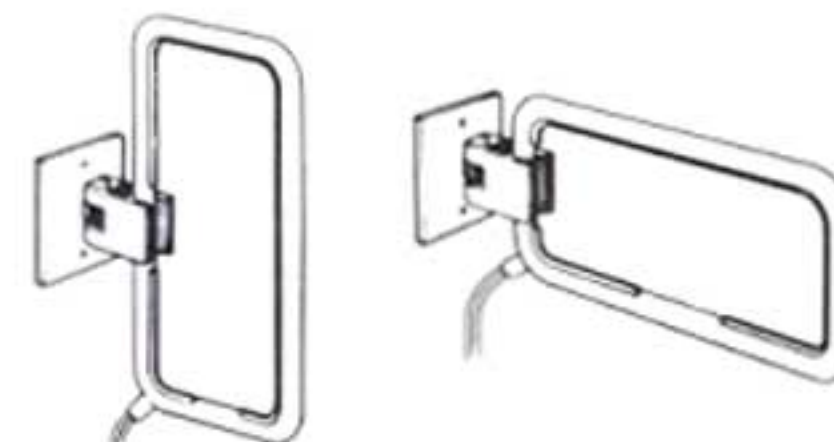
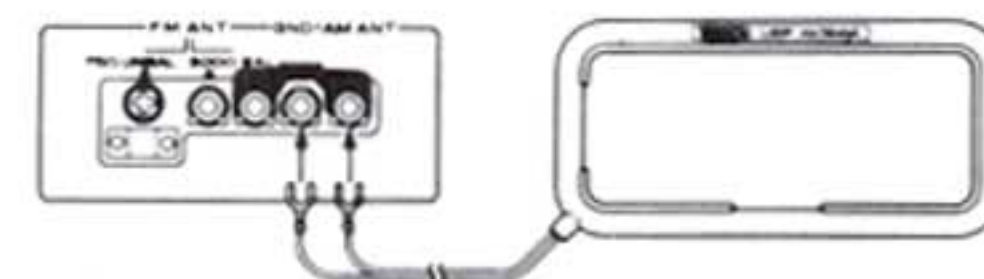

Fig. 12



Note: Always be sure to remove the loop antenna when using the combination bar.

Always be sure to remove the combination bar when connecting the loop antenna.

Fig. 13

Point the antenna in the direction in which strong, noise-free signals are received.

Rear panel

Wall

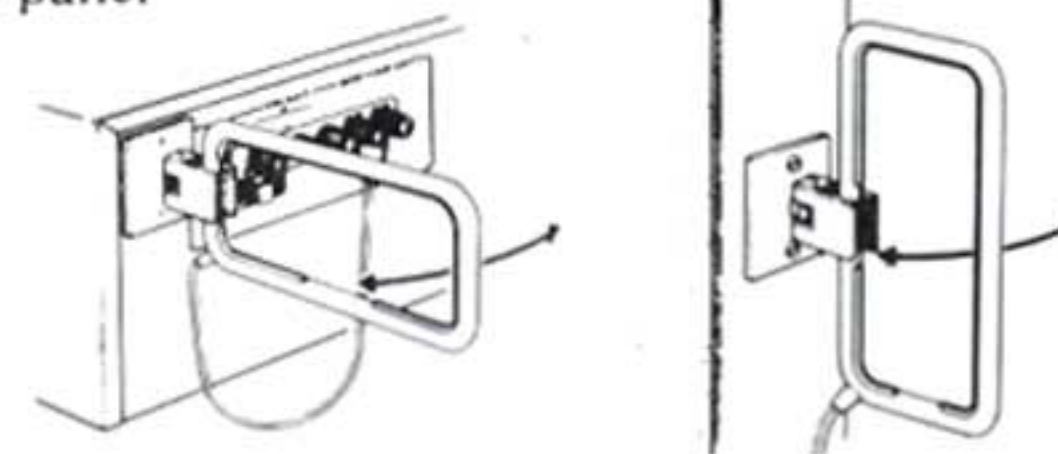

CONNECTING A TURNTABLE

The main AC supply plug of your turntable unit may be conveniently inserted into the "switched" AC outlet socket which is coupled to the CR-2040 POWER switch. With some turntables it is important not to disconnect the main power supply without first switching off at the turntable itself (read the turntable instruction manual to check). In this case you should use one of the two unswitched AC outlets. The pin plugs on the output leads from the turntable should be connected to the PHONO terminal pin jacks at the left-hand side of the rear panel. Check that the L and R pin plugs (for the left and right channels) have been correctly inserted. Do not forget to connect the turntable ground line to the GND terminal on the CR-2040 rear panel. Switch on the POWER switch, and set the INPUT SELECTOR to PHONO, then select the appropriate PHONO selector position. That is, set it to the MC AMP position if you use an MC cartridge; and set it to the 47k Ω position if you use an MM cartridge with 47k Ω impedance. The 47k Ω is best with many MM cartridges, but some will sound better if you use the 33, 68 or 100k Ω . Follow the cartridge manufacturer's recommendations, or in the absence of these, see which setting gives the best tonal balance. The differences are quite subtle. Note that the PHONO input pin-plugs

should never be connected or disconnected while the POWER switch is ON. Always cut the speakers by switching the SPEAKER selector to the OFF position or set the AUDIO MUTING switch to ON when raising or lowering the cartridge stylus in order to prevent overloading and possible damage. If you play monaural records, the signal-to-noise ratio will be improved if you push the MODE switch to the MONO position.

If you notice a low-pitched rumble when playing records, cut this out with the LOW filter. Similarly you can use the HIGH filter to reduce unpleasant surface noise or record 'scratch'. Use the BASS, PRESENCE and TREBLE, controls to give the best tonal balance, and use the LOUDNESS volume control rather than the main volume control to reduce listening levels below your normal maximum.

Fig. 14 Turntable Connections

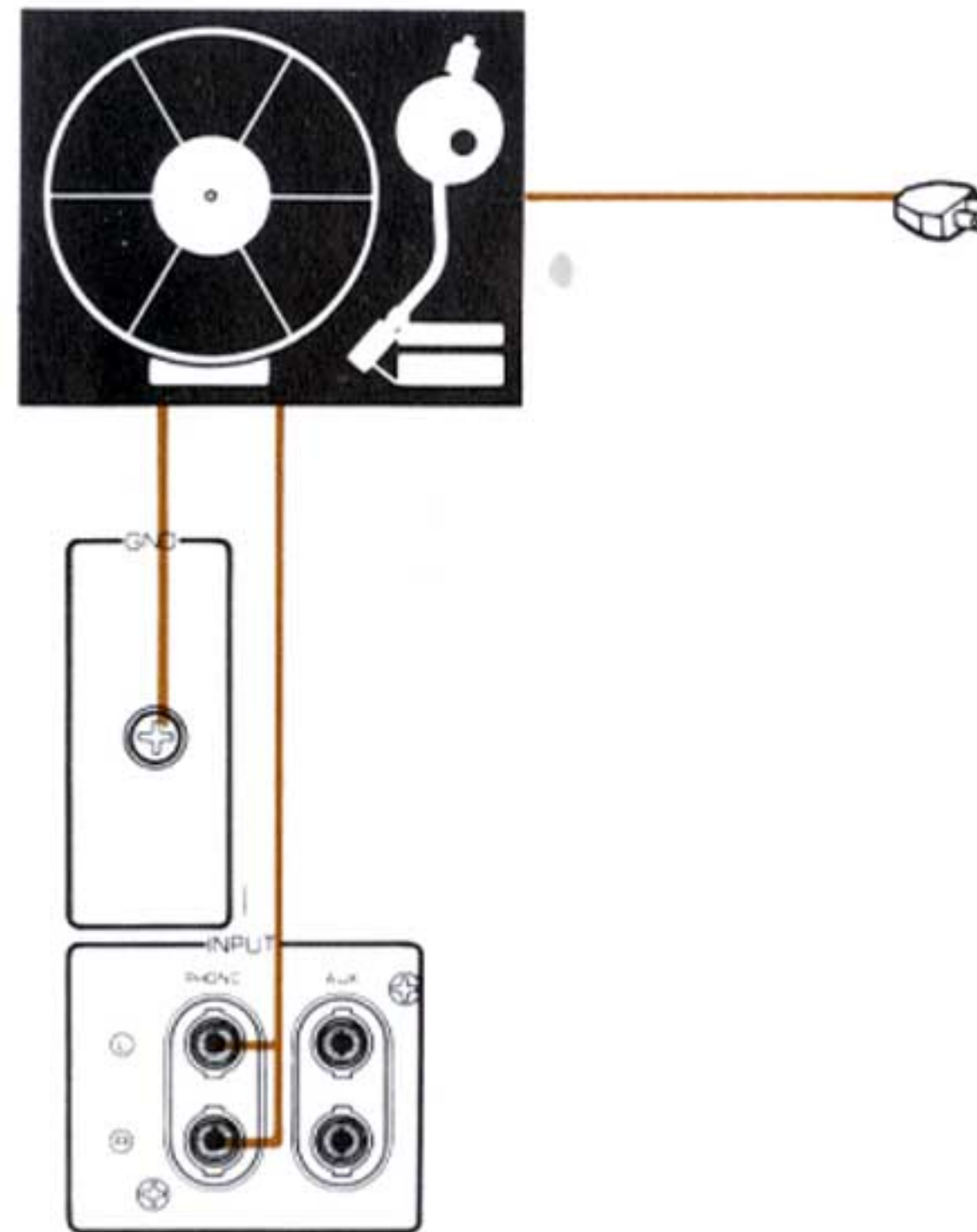
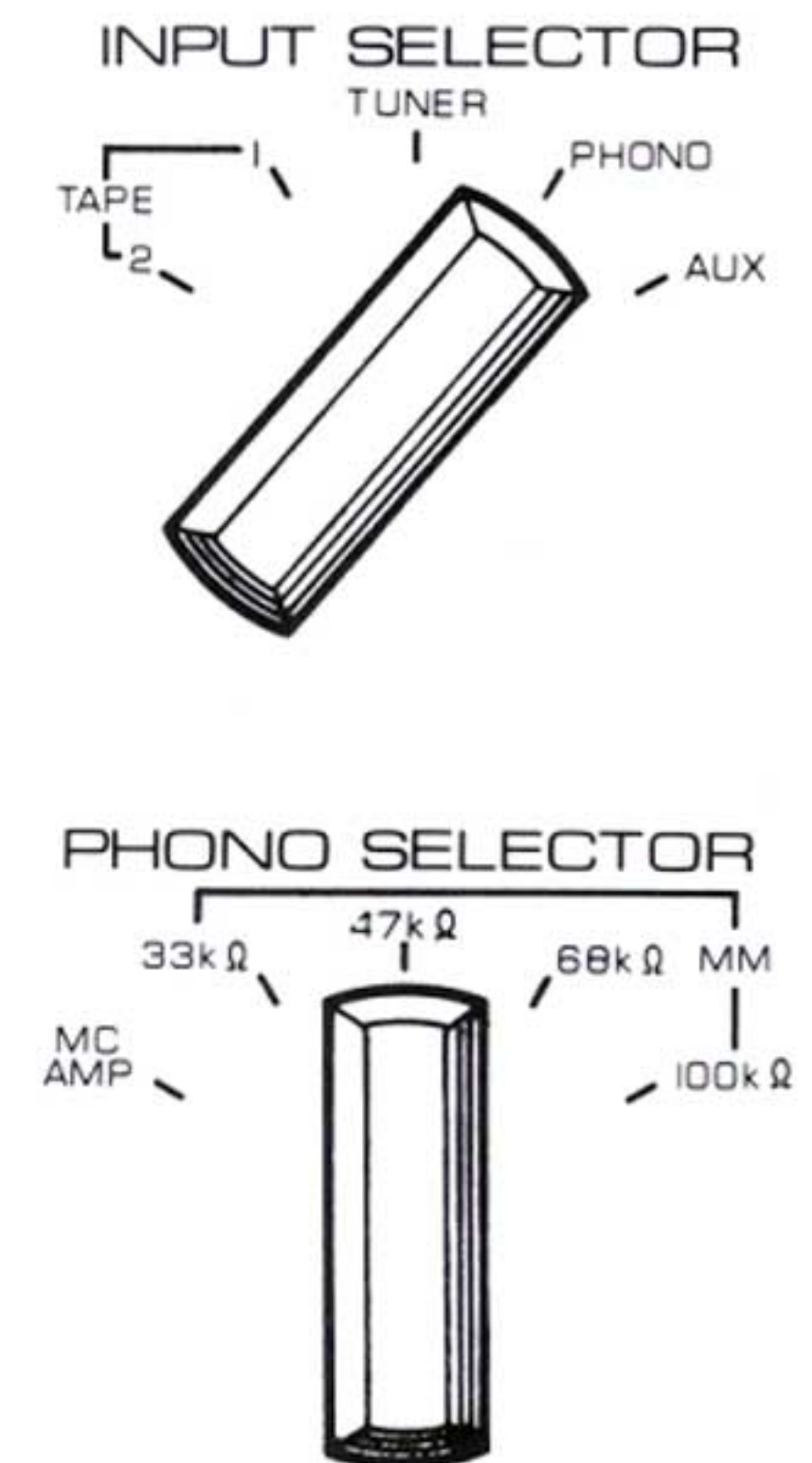

Fig. 15 INPUT SELECTOR and PHONO Selector Settings



CR-2040

LOUDNESS CONTROL AND TONE CONTROLS

CONTINUOUS LOUDNESS CONTROL

Set this to the FLAT position for listening at normal volume levels. The LOUDNESS compensation circuitry enables the same subjective tonal balance to be retained at lower listening levels when this control is turned down.

COMPREHENSIVE TONE CONTROLS

The CR-2040 features three separate tone controls – BASS and TREBLE with the turnover frequency for each control being adjustable to any desired value within specified ranges (100Hz ~ 500Hz for BASS, and 2kHz ~ 10kHz for TREBLE); and PRESENCE with the peak frequency for boosting and attenuation adjustable within the range of 1kHz to 5kHz. The CR-2040 may thus be adjusted to cope with variations in different listening room conditions, and with subtle differences in program material. The FLAT position for each control functions as a DEFEAT position with completely flat response.

Fig. 16

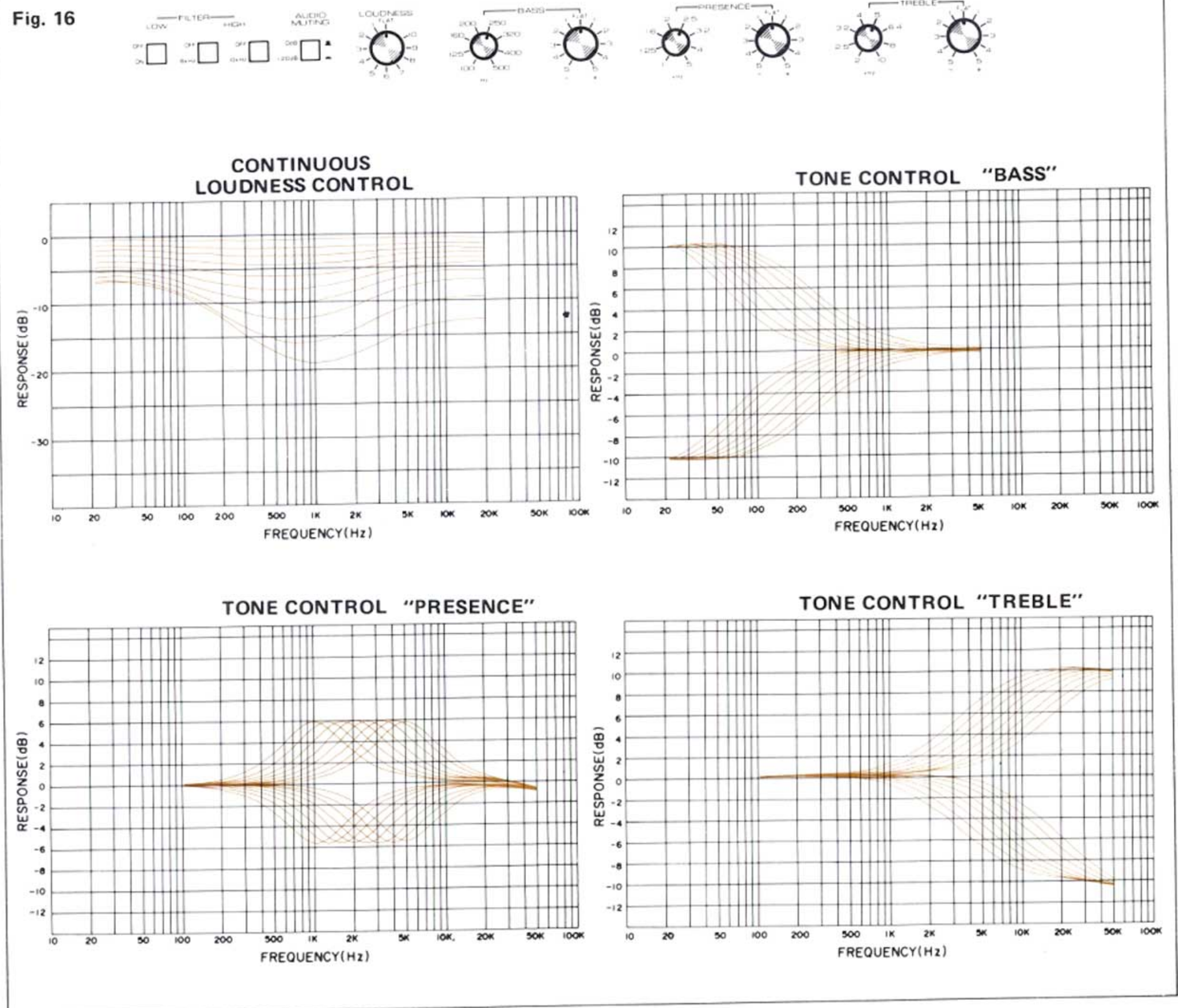

CR-2040

REC OUT SELECTOR

REC OUT SELECTOR

Do not confuse the REC OUT and INPUT SELECTOR switch. The INPUT SELECTOR decides which program source you hear. The REC OUT SELECTOR decides which one you record. Yamaha receivers are at present unique in offering independent choice of auditioning and recording. Thus you can listen to a record while tape-recording direct from the AM/FM tuner section, or while dubbing from one tape deck to another (set the INPUT SELECTOR to PHONO, and REC OUT to TUNER, TAPE 1 2, or TAPE 2 1 positions). Alternatively, you can tape-record a disc while listening to an FM broadcast or a music tape played back on a second tape deck (but be careful that you do not infringe copyright laws by tape-recording proprietary material). Just set the REC OUT SELECTOR to PHONO and the INPUT SELECTOR to TUNER or TAPE 1 (or 2) respectively.

Fig. 17
Recording One Program Source While
Listening to Another

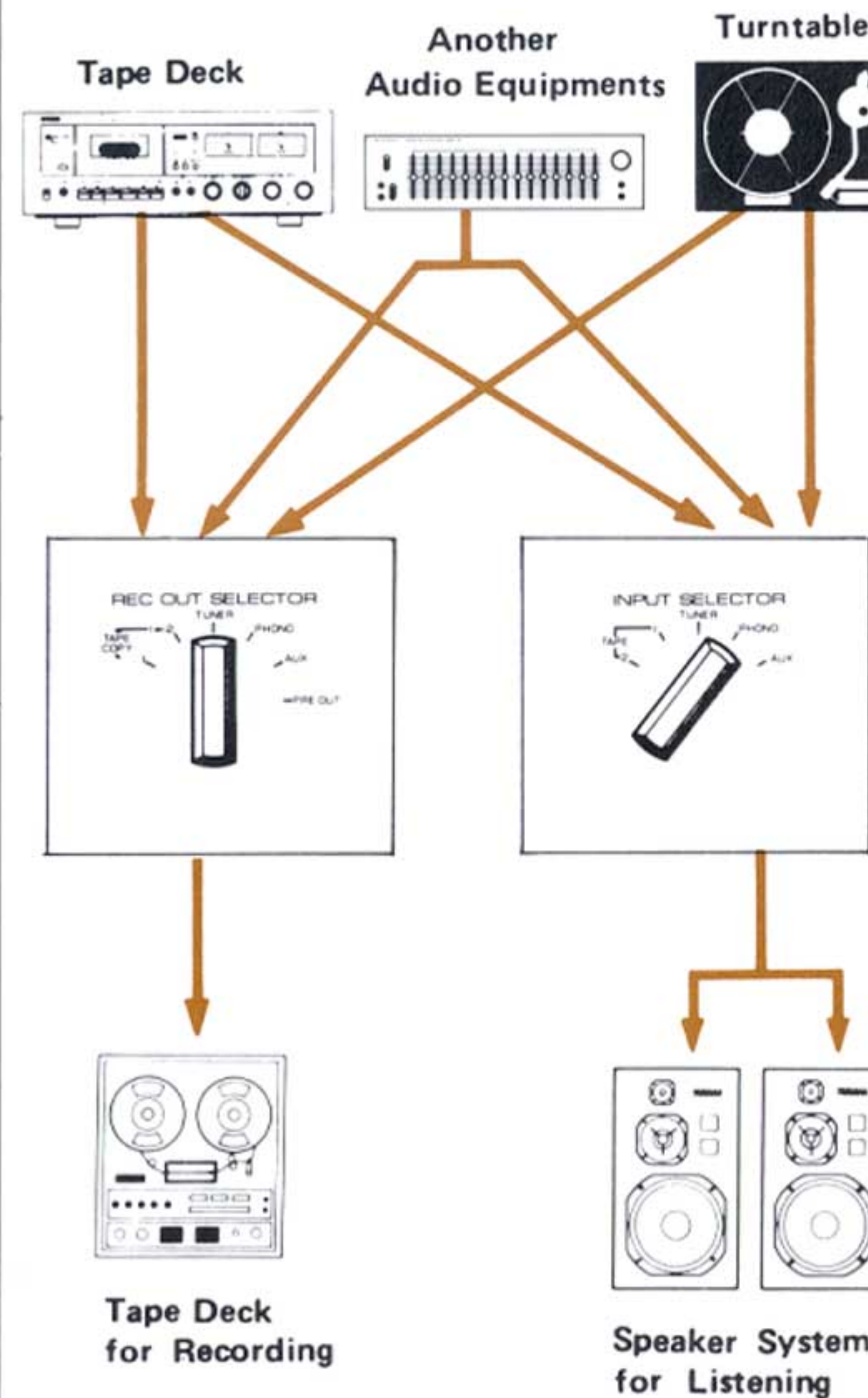

Typical examples:

INPUT SELECTOR	REC OUT SELECTOR	Speakers
PHONO	TUNER	You can record an FM or AM broadcast while listening to a disc through speakers.
TUNER	TUNER	You can record an FM or AM broadcast while listening to it.
PHONO	PHONO	You can listen to a disc through speakers while recording it.
TUNER	PHONO	You can record a disc while listening to an FM or AM broadcast.

Fig. 18 Rec Out Selector & Input Selector Setting

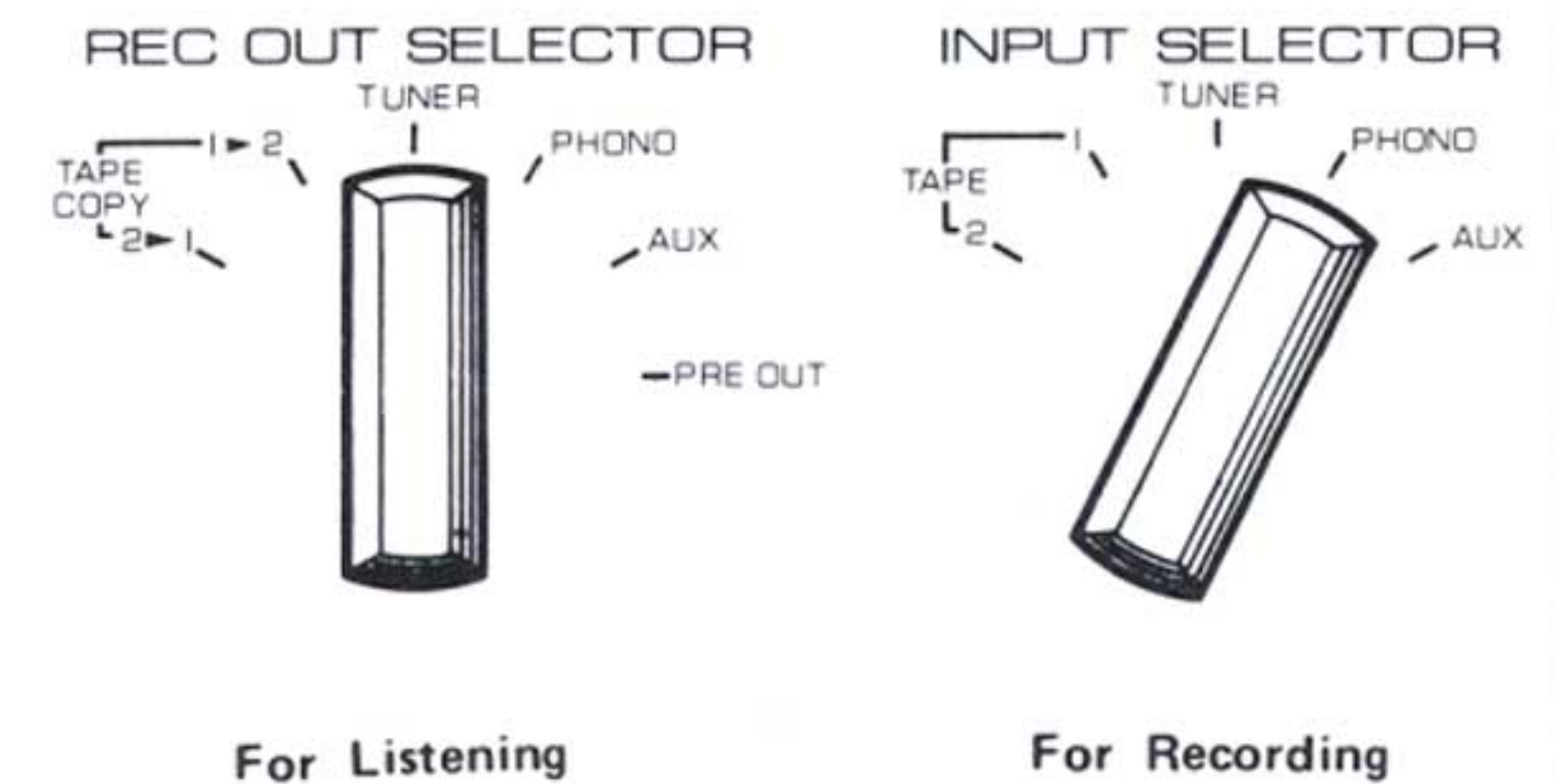

CR-2040

TAPE DECK CONNECTION

TAPE DECK CONNECTION/PLAYBACK

The cords provided with the Tape Deck are used to connect the deck's LINE OUT terminals to the TAPE PB terminals. Use the TAPE 1 terminals for your main deck. Use the TAPE 2 terminals for a second deck or as a spare pair. Set the INPUT SELECTOR to TAPE 1 to play back tapes (or to TAPE 2 if you are using the TAPE 2 terminals, of course).

RECORDING

The cords provided with the tape deck are used to connect the deck LINE IN terminals to the REC OUT terminals. Again, you should use the TAPE 1 terminals for your main deck, keeping the TAPE 2 terminals for a second or spare pair.

Note that the INPUT SELECTOR setting has *no effect* upon the signal which will be recorded via these terminals. REC OUT SELECTOR set to PRE OUT allows signals of a program source selected through INPUT SELECTOR go out from REC OUT terminals. The REC OUT terminals: signal is decided by the REC OUT SELECTOR.

TAPE DUBBING (TAPE COPY)

The CR-2040 provides for dubbing from tape to tape with the tape decks 1 and 2 connected to the TAPE-1 and -2 terminals respectively. To dub from the tape deck 1 to the tape deck 2, place the REC OUT SELECTOR in the TAPE COPY 1 ► 2 position as shown in Fig. 20, and operate the tape deck 1 in the playback mode and the tape deck 2 in the recording mode.

To dub from the TAPE-2 to the TAPE-1, place the REC OUT SELECTOR in the TAPE COPY 2 ► 1 position, and operate the tape decks 1 and 2 in the recording and playback modes respectively.

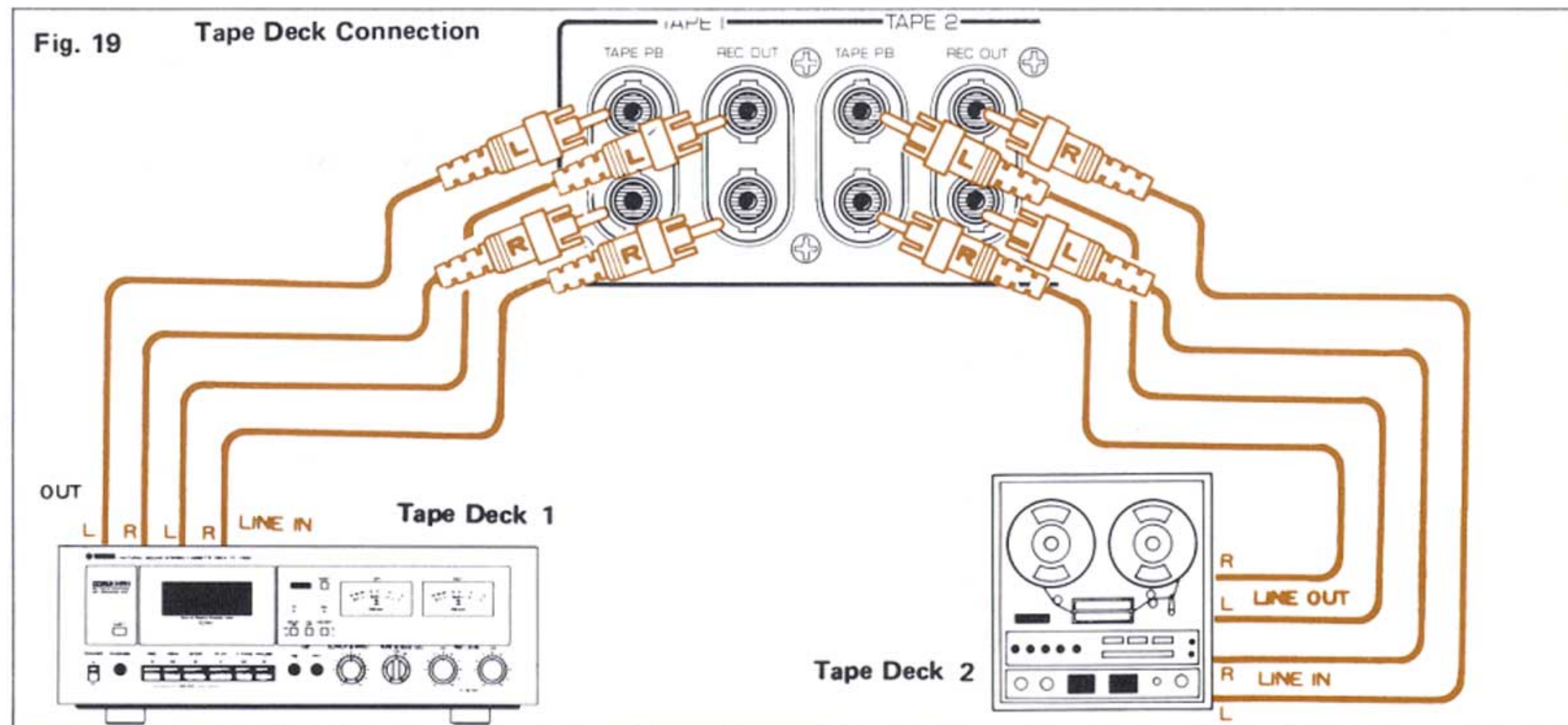
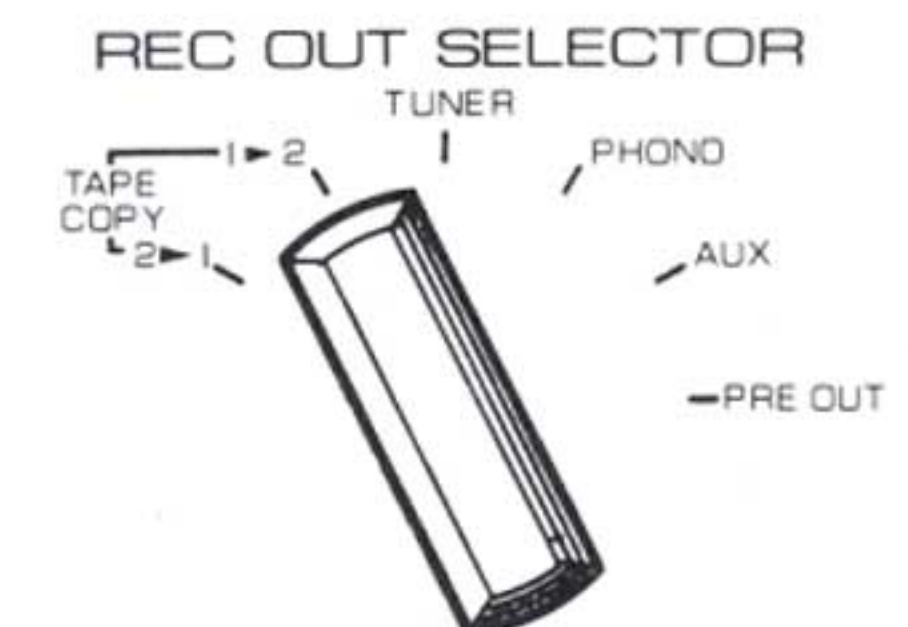

Fig. 20 **Rec Out Selector Setting**



HIGH AND LOW FILTER

A sharp 12 dB/octave (LOW) cut-off and 6 dB/oct (HIGH) cut-off slope with low distortion ensure negligible tonal deterioration in the important frequency regions which carry most of the musical signals. These filters effectively remove sub-sonic rumble and high frequency tape hiss or record surface noise.

High Filter

The two HIGH frequency filters commence their cut-offs at 6kHz to 8kHz. They can be used to cut out unwanted tape hiss or record scratch (which becomes more obtrusive at higher frequencies). The use of the 6kHz filter involves considerable sacrifice of the brilliant upper harmonics which add character to brass and stringed instruments. This is also true, but to a lesser extent, with the 8kHz filter. Only you can decide whether the program source is more enjoyable with—or preferably without—these filters.

Fig. 21

Filters Characteristics

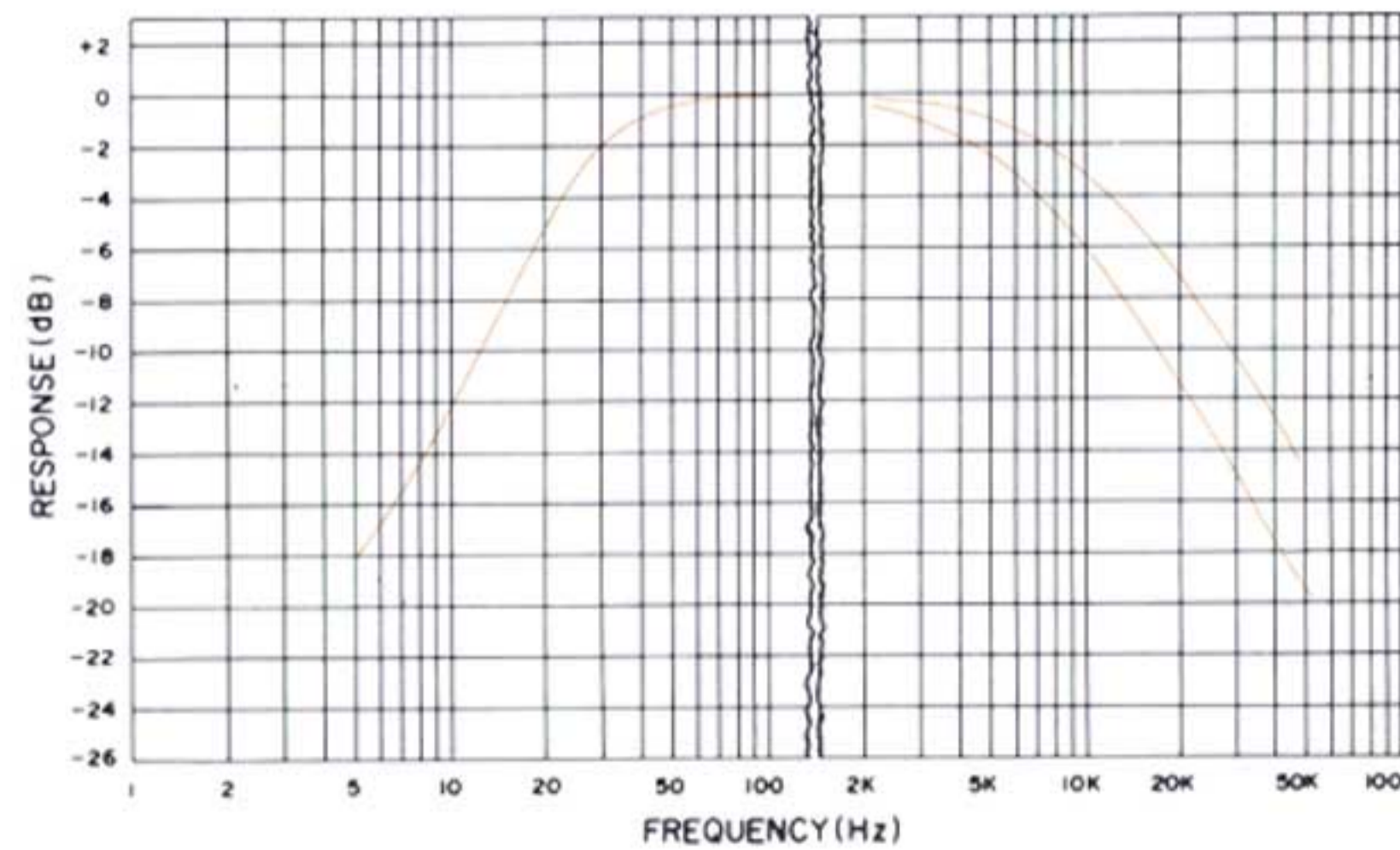
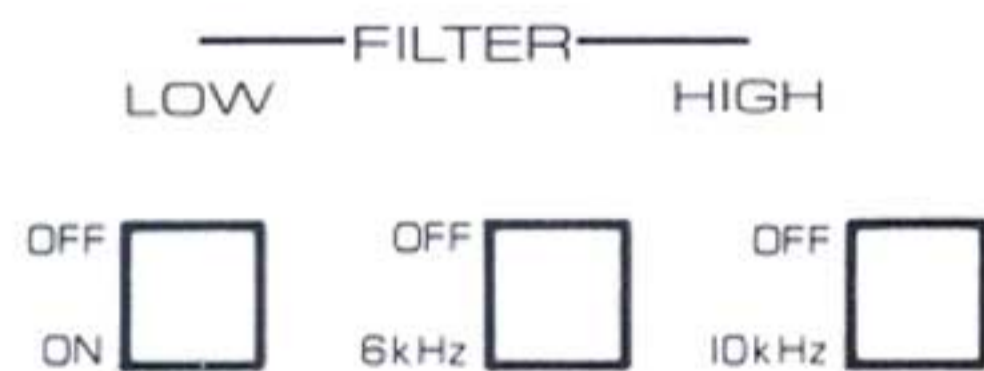

ADAPTOR SWITCH

When using Graphic Equalizer, Dolby Unit or any other audio equipment, connect it as shown in the figure below and turn ADAPTOR switch on the front panel to ON.

Fig. 22

ADAPTOR

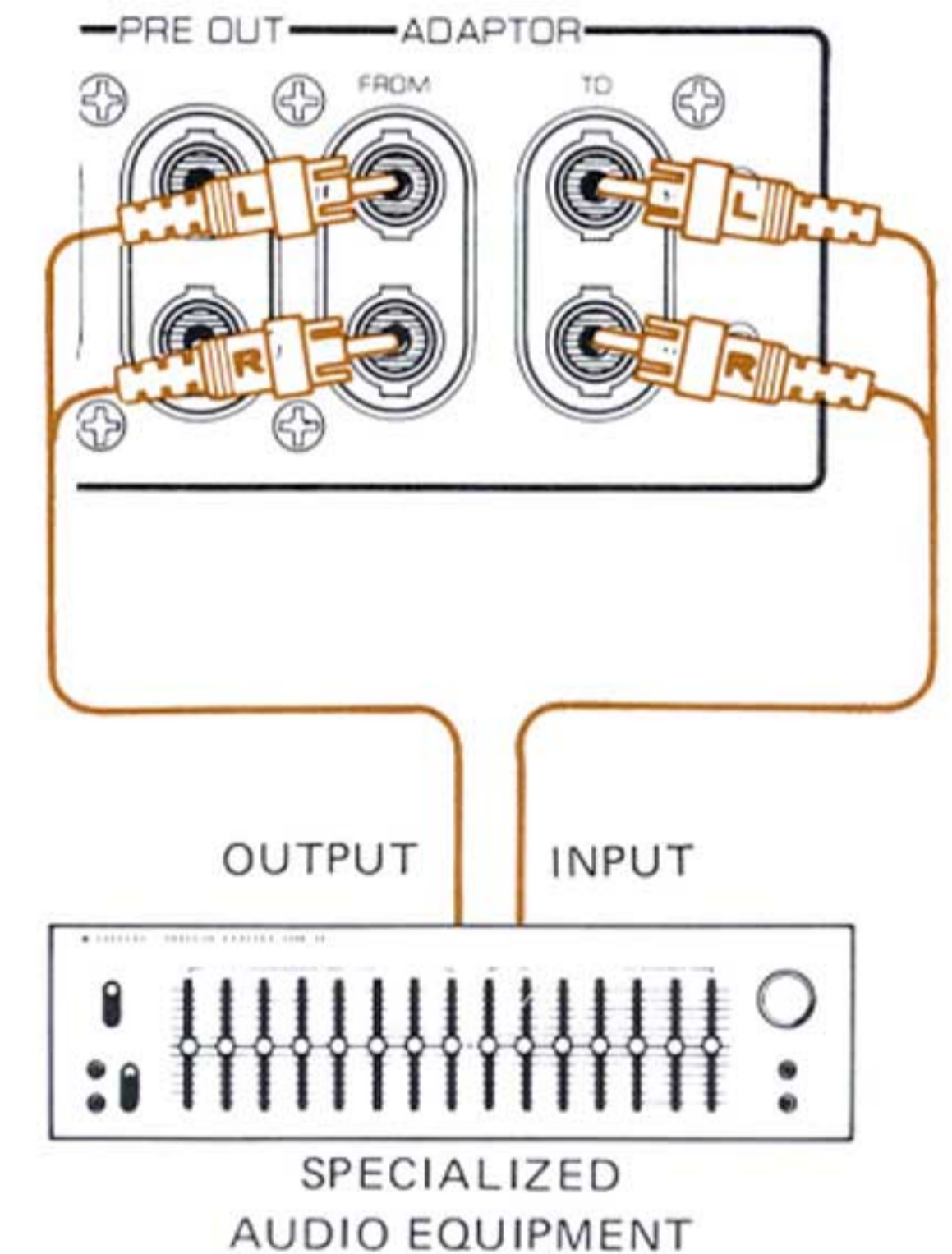
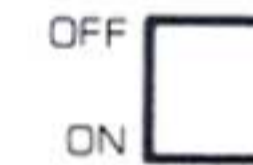

CR-2040

SPECIFICATIONS

AUDIO SECTION

Minimum RMS Output Power per Channel

120 Watts (8 ohms) from 20 to 20,000 Hz at no more than 0.02% Total Harmonic Distortion

140 Watts (8 ohms) at 1 kHz at no more than 0.02% Total Harmonic Distortion

Input Sensitivity/Impedance

Phono (MM)	2.5 mV/33, 47, 68, 100 k Ω
Phono (MC)	100 μ V/50 Ω
Aux, Tape 1, 2	120 mV/40 k Ω

Maximum Input Levels

Phono (MM)	270 mV (at 1 kHz)
Phono (MC)	11 mV (at 1 kHz)

Output Level/Impedance

Rec Out terminals	120 mV/220 Ω
-------------------	---------------------

Frequency Response

Phono (MM, MC) RIAA deviation	\pm 0.2 dB
Aux, Tape 1, 2	20 Hz to 20 kHz \pm 0.2 dB
	5 Hz to 100 kHz +0.2dB, -2 dB

Tone Control Characteristics

Bass turnover frequencies	100 ~ 500 Hz (continuous)
Bass boost/cut	\pm 10 dB
Treble turnover frequencies	2 ~ 10 kHz (continuous)
Treble boost/cut	\pm 10 dB
Presence center frequencies	1 ~ 5 kHz (center)
Presence boost/cut	\pm 6 dB

Filters and Loudness Control Characteristics

Low	25 Hz (12 dB/octave)
High 1, 2	6, 8 kHz (6 dB/octave)
Loudness control	Level-related equalization

Signal-to-Noise Ratio (IHF-A Network)

Phono (MM)	95 dB (for 10 mV, shorted)
Phono (MC)	86 dB (for 500 μ V)

Aux, Tape	100 dB (shorted)
Residual noise (at Vol Min)	0.22 mV
Distortion 20 Hz to 20 kHz	
Phono (MM) to Rec Out	0.01% 3V output
Phono (MC) to Rec Out	0.05% 3V output
Aux, Tape to Sp Out (8 Ω)	0.01% 60 W/8 Ω
Intermodulation Distortion Ratio 20 Hz to 20 kHz (70 Hz : 7 kHz = 4 : 1)	
Sp Out	0.02% 120 W/8 Ω
	0.01% 60 W/8 Ω

Noise-Distortion Clearance Range (NDCR) for 0.1% into 8 Ω at 1 kHz

Phono	MC 100 mW to 120 W
	MM 20 mW to 120 W

Power Bandwidth (IHF)

	10 Hz to 50 kHz (8 Ω , 0.05%)
--	--------------------------------------

Damping Factor (at 1 kHz)

	40 into 8 Ω , 1 kHz
--	----------------------------

Meter Range

	0.01 W to 300 W
--	-----------------

FM SECTION

Tuning range	87.6 to 108 MHz
--------------	-----------------

Usable Sensitivity (IHF Mono 98 MHz)

300 Ω	1.6 μ V/9.3 dBf (30% Dev.)
75 Ω	0.8 μ V/9.3 dBf

50 dB Quieting Sensitivity

Mono	3.2 μ V/15.3 dBf
Stereo	35 μ V/36.1 dBf
Auto	25 μ V/33.2 dBf

Signal-to-Noise Ratio

Mono (65 dBf)	90 dB
Stereo (75 dBf)	84 dB

Image Response Ratio (98 MHz)

	80 dB
--	-------

IF Response Ratio (98 MHz)

	100 dB
--	--------

Spurious Response Ratio (98 MHz)

	100 dB
--	--------

AM Suppression Ratio (IHF)

	60 dB
--	-------

Capture Ratio

	1.5 dB
--	--------

Alternate Channel Selectivity DX

	82 dB
--	-------

Local

	48 dB
--	-------

Distortion (at 65 dBf)		
Mono	100 Hz	0.07%
	1 kHz	0.07%
	6 kHz	0.1%
Stereo	100 Hz	0.09%
	1 kHz	0.09%
	6 kHz	0.15%
Intermodulation Distortion (IHF)		
Mono		0.05%
Stereo		0.07%
Stereo Separation		
50 Hz		50 dB
1 kHz		50 dB
10 kHz		45 dB
Blend		10 dB
Subcarrier Product Ratio		70 dB
Frequency Response		
50 Hz to 10 kHz		±0.4 dB
30 Hz to 15 kHz		+0.4 dB, -1.0 dB
Muting Threshold (±22.5 kHz dev.)		5 μV (19.2 dBf)
AM SECTION		
Tuning Range		525 to 1,605 kHz
Sensitivity (IHF)		15 μV/m
Selectivity (1,000 kHz)		30 dB
Signal-to-Noise Ratio		50 dB (at 80 dB/m)
Image Response Ratio (1,000 kHz)		40 dB
IF Response Ratio (1,000 kHz)		35 dB
Spurious Response Ratio (1,000 kHz)		60 dB
Distortion (at 65 dBf)		0.4% (at 80 dB/m, 120 dB/m)
Tuner Section Output Level/Impedance		
FM (100% mod. at Rec Out)		450 mV/3.9 kΩ
AM (30% mod. at Rec Out)		150 mV/3.9 kΩ

GENERAL

Semiconductors	102 Transistors, 14 ICs, 4 FETs, 31 Diodes, 9 Zener Diodes, 9 LEDs
Power Supplies	U.S. & Canadian AC 120V, 60Hz
Power Consumption	U.S. Model 600 W Canadian Model 800 VA
AC Outlets	Switched 200 W max. Unswitched 200 W max.
Dimensions (W x H x D)	580 x 167 x 407 mm (23" x 6-5/8" x 16-1/8")
Weight	20.4 kg (45 lbs.)

Specifications subject to change without notice.

CR-2040

BLOCK DIAGRAM

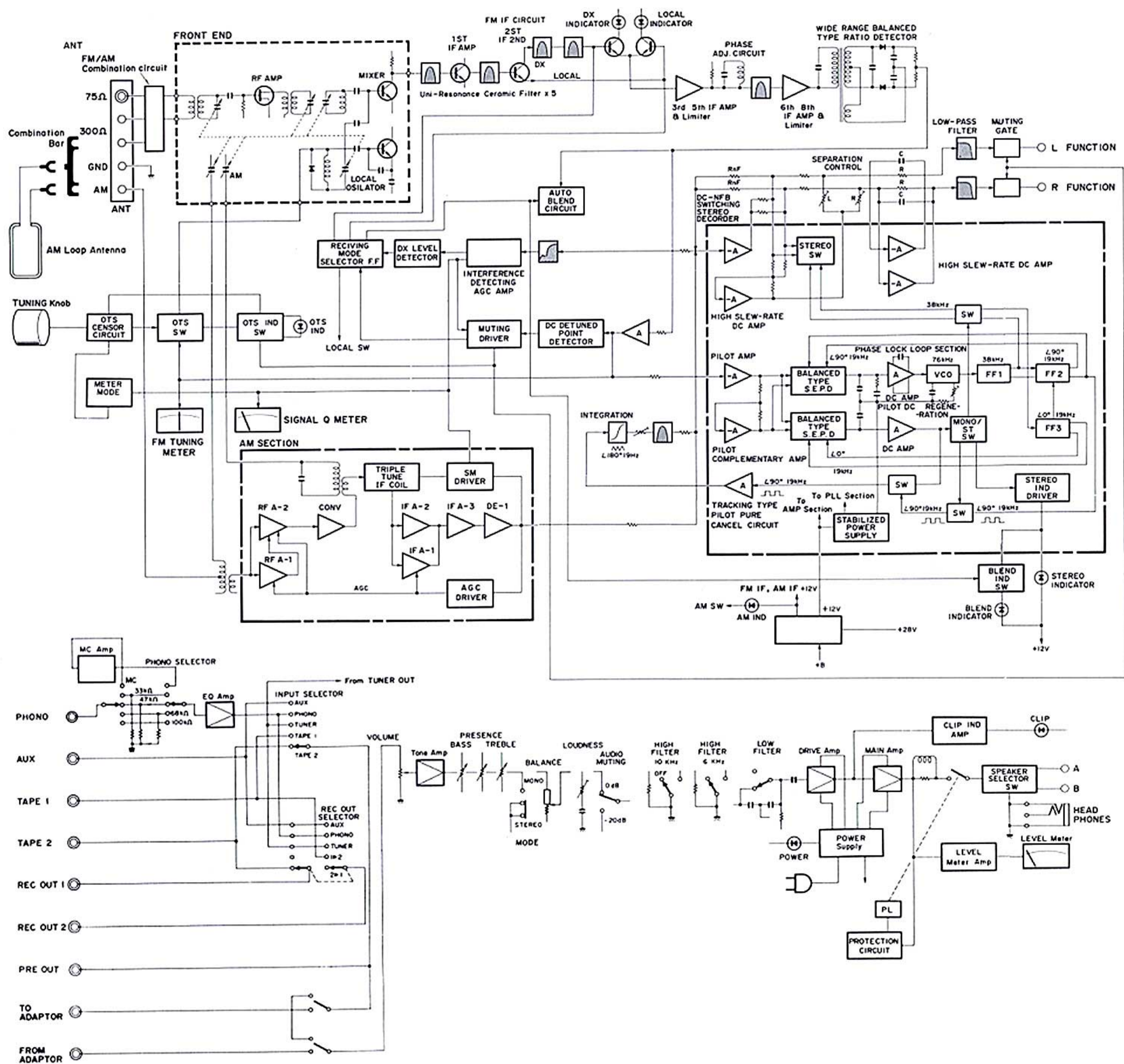

CR-2040

SCHEMATIC DIAGRAM

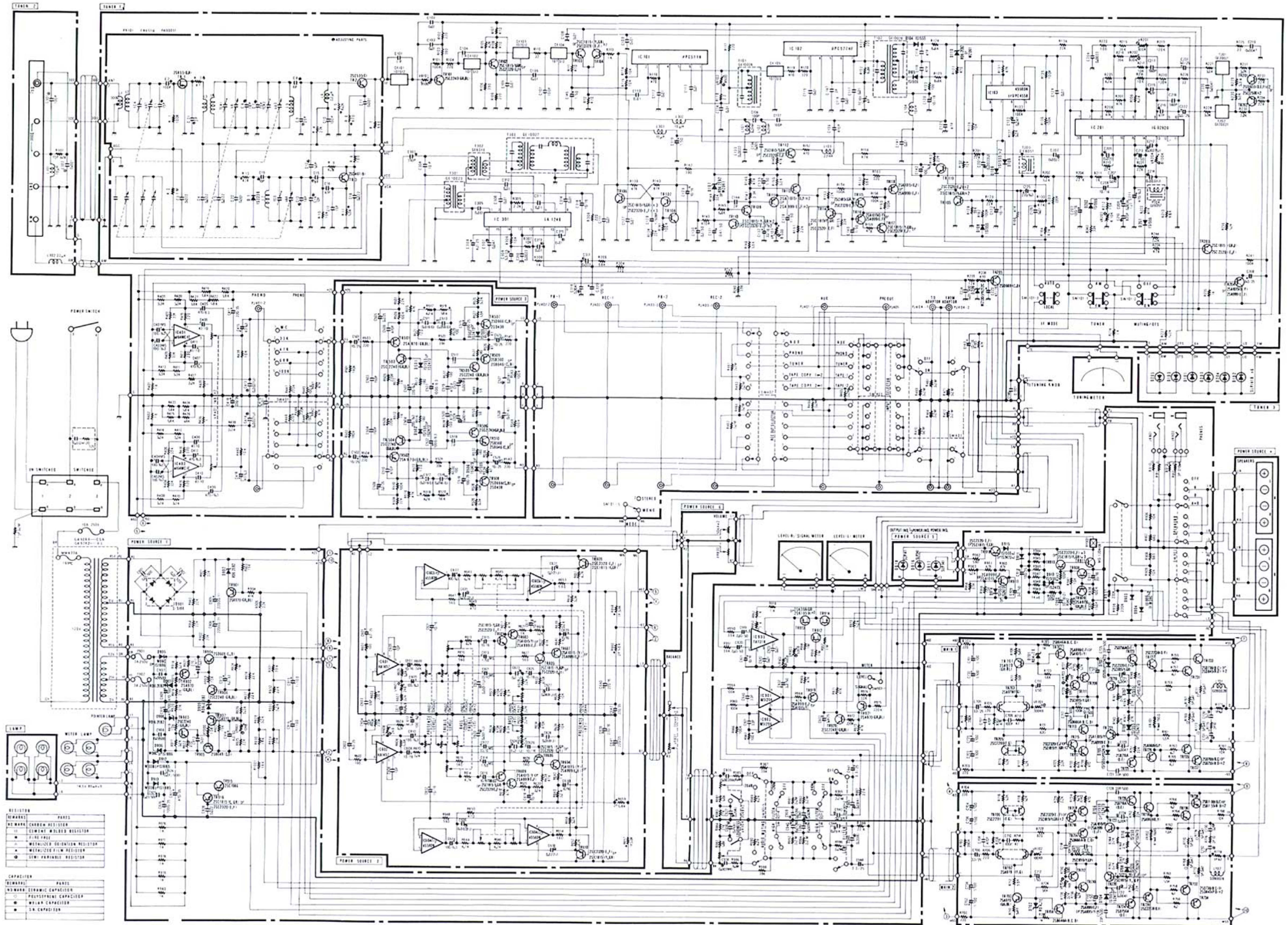

Before assuming that your CR-2040 is faulty, check this double-sided trouble-shooting list. It details many steps you can take yourself without having to call a service representative. Keep it near your CR-2040 for ready reference.

TUNER SECTION

Fault	Cause	Cure
A persistent hum occurs when an AM station is tuned.	This hum can affect whole areas where broadcast conditions are unfavorable.	Sometimes changing the position of the CR-2040 will give an improvement.
Intermittent crackling or continuous background 'roaring' on AM.	Atmospheric electricity or electrical storms, possibly fluorescent lighting or other electrical equipment.	Difficult to eliminate, an external antenna and good ground connection will give considerable improvement.
High pitched whistles, etc., particularly at night on AM.	Signals from adjacent stations are interfering with reception. The CR-2040 is being operated too near a TV set.	Nothing can be done to cut out this interference completely but try the HIGH filter. Increase the separation between the TV and the CR-2040.
The desired station cannot be received at the correct frequency on the dial.	The station strength may be low, and the MUTING circuit may therefore prevent audition.	Switch the MUTING/OTS from ON to OFF.
A stereo station is heard monaurally.	The MODE switch is set to MONO.	Push and release to the STEREO position.
Occasional crackling interference (particularly with remote, weak signal stations).	Electrical noise from automobiles, etc., or from other electrical equipment.	Set up an external FM antenna, as high and as far from the road as convenient: use coaxial cable. Fit an interference suppressor to the offending item where possible.
Disturbing levels of 'hiss' noise when on FM stereo stations.	FM stereo broadcasts are inherently more liable to this at remote, low signal strength locations.	Set up an external FM antenna: if you are already using one, orient it towards the station or replace with a more sensitive array. Alternatively or additionally, listen with the MUTING/OTS switch set at OFF.
Local stations suffer from unclear, distorted sound.	Signal input from the antenna for these stations is too strong.	Connect an attenuator between the FM antenna and the CR-1040, or turn the antenna away from the strongest (closest) station.
During stereo test transmissions, sounds which should come from only one channel can be heard faintly over the other.	This is known as crosstalk, and normally occurs to some extent.	Provided the sound level is very faint compared with the normal level for that channel, no fault is indicated.

AUDIO SECTION

Fault	Cause	Cure
No power although POWER switch in ON (POWER LED unlit).	AC power line not plugged-in to supply socket. AC mains fuse has blown.	Plug firmly into the supply socket. Contact your service representative for a replacement.
No sound although power LED lights.	When other equipments are not connected, set ADAPTOR switch to ON. Volume too low. INPUT SELECTOR in wrong position. Input pin plugs incorrectly inserted, loose, or disconnected. Speaker connections faulty. SPEAKER switch in wrong position.	Set to OFF the ADAPTOR switch, or connect other equipments. Turn up volume. Check and change as necessary. Check and insert fully in the correct position. Check and make good. Set one or both (A, B, or A + B).
Sound comes only, or mainly, from either L or R speaker.	Speaker connections faulty. Input connections faulty. BALANCE control not properly adjusted.	Check and make good. Check and make good. Set to give correct stereo balance.
Sound suddenly ceases.	The protective circuit has gone into operation.	Check for incorrect (too low) speaker impedance or short circuits and correct. If the fault persists, switch off and wait briefly before switching on again.
Poor bass response and badly defined stereo image. A loud 'hum' is heard with, or instead of, the record when attempting PHONO audition.	Speaker + and – connections are incorrect. Either the pin-plugs from the phono cartridge are not firmly plugged into the input sockets, or the braided shielding wire is defective.	Reverse the connections to one speaker, not both. Plug in firmly, replacing the defective shielding if necessary. Check and make good the GND (ground) wire connection.
The volume control cannot be raised during record audition without a loud 'booming' noise.	This is caused by feedback of sound from the speakers to the phono cartridge stylus, and is called acoustic feedback.	Increase the separation between turntable and speakers, avoiding locations directly in line with the speakers.
Bass and treble frequencies are unnaturally exaggerated.	The LOUDNESS control is set too low.	Turn to the FLAT position (fully clockwise) and reset main volume and LOUDNESS controls according to the instructions.
Your tape recorder does not record the program you are monitoring.	The REC OUT selector is not set to the required program source.	Turn to the required setting.

SINCE 1887  **YAMAHA**
NIPPON GAKKI CO., LTD. HAMAMATSU, JAPAN